

KPC-1530/1730

Fanless Industrial Panel PC with
Intel® Atom N270 + Intel® 945GSE/ ICH7-M

User's Guide



Contact Info: **Quanmax Inc.**
5F, No. 415, Ti-Ding Blvd. Sec. 2, NeiHu District,
Taipei, Taiwan 114
Tel: +886-2-2799-2789
Fax: +886-2-2799-7399

Visit our site at: **www.quanmax.com**

© 2009 Quanmax Inc. All rights reserved.

The information in this user's guide is provided for reference only. Quanmax does not assume any liability arising out of the application or use of the information or products described herein. This user's guide may contain or reference information and products protected by copyrights or patents and does not convey any license under the patent rights of Quanmax, nor the rights of others.

Quanmax is a registered trademark of Quanmax. All trademarks, registered trademarks, and trade names used in this user's guide are the property of their respective owners. All rights reserved. This user's guide contains information proprietary to Quanmax. Customers may reprint and use this user's guide in other publications. Customers may alter this user's guide and publish it only after they remove the Quanmax name, cover, and logo.

Quanmax reserves the right to make changes without notice in product or component design as warranted by evolution in user needs or progress in engineering or manufacturing technology.

Changes which affect the operation of the unit will be documented in the next revision of this user's guide.

Revision	Date	Edited by	Changes
1.0	07/22/2009	SLee	Initial Release
1.01	08/24/2009	SLee	Packing List Updated
1.02	09/15/2009	SLee	HDD & ODD Installation Update
1.03	12/16/2009	SLee	Correct RS232/422/485 pin assignment



Content

Content.....	3
Figures	4
Tables.....	5
Safety Instructions.....	6
Before You Begin	6
When Working Inside a Computer	6
Preventing Electrostatic Discharge	7
Preface.....	8
How to Use This Guide	8
Unpacking.....	8
Regulatory Compliance Statements.....	8
Warranty Policy.....	9
Maintaining Your Computer.....	10
Chapter 1 Introduction	13
Overview.....	13
Product Specifications	14
Mechanical Layout.....	15
Chapter 2 Assembly/Disassembly	18
Accessing Internal Components	18
Memory Module Installation.....	19
Installation PCI Card.....	20
HDD & ODD Installation.....	22
VESA Mounting.....	23
Wall Mounting	24
Panel Mounting.....	25
Chapter 3 Getting Started	27
Power Connection	27
Operating System and Drivers.....	28
Chapter 4 Maintenance and Prevention	29
Chapter 5 Interface & Jumper Setting.....	30
External Connectors	30
Jumper Setting.....	32

Figures

Figure 1 Mechanical Layout - Front and Side	15
Figure 2 Mechanical Layout - I/O Panel.....	15
Figure 3 Mechanical Dimensions (KPC-1530)	16
Figure 4 Mechanical Dimensions (KPC-1730)	17
Figure 5 Removing the rear cover.....	18
Figure 6 Mechanical Internal Layout	19
Figure 7 Align the SO-DIMM Memory Module with the onboard socket.....	19
Figure 8 Press down on the SO-DIMM Memory Module to lock it in place	20
Figure 9 PCI card height restrictions.....	20
Figure 10 HDD & ODD Installation.....	22
Figure 11 Mounting hole locations	23
Figure 12 Wall Mounting Demonstrations	24
Figure 13 Panel Mount Cut-out hole and maximum panel thickness	25
Figure 14 Panel Mounting.....	26
Figure 15 Jumper and Connector Locations	33

Tables

Table 1 Specifications	14
Table 2 AUDIO, 3-Port Audio phone jack	30
Table 3 USB, USB2.0 Type A Connector.....	30
Table 4 LAN, Ethernet RJ-45 Connector	30
Table 5 COM1 RS-232/422/485 Connector (DB9)	31
Table 6 COM2-4 RS-232 Connector (DB9).....	31
Table 7 VGA Connector (DB15)	31
Table 8 CN 10, PS/2 KB/MS Connector	32
Table 9 JP4, COM1 Signal / Power Selection.....	32
Table 10 JP5/ 6/ 7, COM2/ 3/ 4 Signal / Power Selection.....	32
Table 11 JP3, Clear CMOS Selection	32

Safety Instructions

■ Before You Begin

Before handling the product, read the instructions and safety guidelines on the following pages to prevent damage to the product and to ensure your own personal safety. Refer to the “Advisories” section in the Preface for advisory conventions used in this user’s guide, including the distinction between Warnings, Cautions, Important Notes, and Notes.

- Always use caution when handling/operating a computer. Only qualified, experienced, authorized electronics service personnel should access the interior of a computer. The power supplies produce high voltages and energy hazards, which can cause bodily harm.
- Use extreme caution when installing or removing components. Refer to the installation instructions in this user’s guide for precautions and procedures. If you have any questions, please contact Quanmax Post-Sales Technical Support.

WARNING



High voltages are present inside the chassis when the unit’s power cord is plugged into an electrical outlet. Turn off system power, turn off the power supply, and then disconnect the power cord from its source before removing the chassis cover. Turning off the system power switch does not remove power to components.

■ When Working Inside a Computer

Before taking covers off a computer, perform the following steps:

1. Turn off the computer and any peripherals.
2. Disconnect the computer and peripherals from their power sources or subsystems to prevent electric shock or system board damage. This does not apply when hot swapping parts.
3. Follow the guidelines provided in “Preventing Electrostatic Discharge” on the following page.
4. Disconnect any telephone or telecommunications lines from the computer.

In addition, take note of these safety guidelines when appropriate:

- To help avoid possible damage to system boards, wait five seconds after turning off the computer before removing a component, removing a system board, or disconnecting a peripheral device from the computer.
- When you disconnect a cable, pull on its connector or on its strain-relief loop, not on the cable itself. Some cables have a connector with locking tabs. If you are disconnecting this type of cable, press in on the locking tabs before disconnecting the cable. As you pull connectors apart, keep them evenly aligned to avoid bending any connector pins. Also, before connecting a cable, make sure both connectors are correctly oriented and aligned.

CAUTION



Do not attempt to service the system yourself except as explained in this user's guide. Follow installation and troubleshooting instructions closely.

■ Preventing Electrostatic Discharge

Static electricity can harm system boards. Perform service at an ESD workstation and follow proper ESD procedure to reduce the risk of damage to components. Quanmax strongly encourages you to follow proper ESD procedure, which can include wrist straps and smocks, when servicing equipment.

You can also take the following steps to prevent damage from electrostatic discharge (ESD):

- When unpacking a static-sensitive component from its shipping carton, do not remove the component's antistatic packing material until you are ready to install the component in a computer. Just before unwrapping the antistatic packaging, be sure you are at an ESD workstation or grounded. This will discharge any static electricity that may have built up in your body.
- When transporting a sensitive component, first place it in an antistatic container or packaging.
- Handle all sensitive components at an ESD workstation. If possible, use antistatic floor pads and workbench pads.
- Handle components and boards with care. Don't touch the components or contacts on a board. Hold a board by its edges or by its metal mounting bracket.
- Do not handle or store system boards near strong electrostatic, electromagnetic, magnetic, or radioactive fields.

Preface

■ How to Use This Guide

This guide is designed to be used as step-by-step instructions for installation, and as a reference for operation, troubleshooting, and upgrades.



NOTE

Driver downloads and additional information are available under Downloads on our web site: www.quanmax.com.

■ Unpacking

When unpacking, follow these steps:

1. After opening the box, save it and the packing material for possible future shipment.
2. Remove all items from the box. If any items listed on the purchase order are missing, notify Quanmax customer service immediately.
3. Inspect the product for damage. If there is damage, notify Quanmax customer service immediately. Refer to “Warranty Policy” for the return procedure.

■ Regulatory Compliance Statements

This section provides the FCC compliance statement for Class A devices.

FCC Compliance Statement for Class A Devices

The product(s) described in this user’s guide has been tested and found to comply with the limits for a Class A digital device, pursuant to Part 15 of the FCC Rules. These limits are designed to provide reasonable protection against harmful interference when the equipment is operated in a commercial environment. This equipment generates, uses, and can radiate radio frequency energy and, if not installed and used in accordance with the user’s guide, may cause harmful

interference to radio communications. Operation of this equipment in a residential area (domestic environment) is likely to cause harmful interference, in which case the user will be required to correct the interference (take adequate measures) at their own expense.

Changes or modifications not expressly approved by Quanmax could void the user's authority to operate the equipment.

NOTE



The assembler of a personal computer system may be required to test the system and/or make necessary modifications if a system is found to cause harmful interference or to be noncompliant with the appropriate standards for its intended use.

■ Warranty Policy

Limited Warranty

Quanmax Inc.'s detailed Limited Warranty policy can be found under Support at www.quanmax.com. Please consult your distributor for warranty verification.

The limited warranty is void if the product has been subjected to alteration, neglect, misuse, or abuse; if any repairs have been attempted by anyone other than Quanmax or its authorized agent; or if the failure is caused by accident, acts of God, or other causes beyond the control of Quanmax or the manufacturer. Neglect, misuse, and abuse shall include any installation, operation, or maintenance of the product other than in accordance with the user's guide.

No agent, dealer, distributor, service company, or other party is authorized to change, modify, or extend the terms of this Limited Warranty in any manner whatsoever.

Quanmax reserves the right to make changes or improvements in any product without incurring any obligation to similarly alter products previously purchased.

Return Procedure

For any Limited Warranty return, please contact Support at www.quanmax.com and login to obtain a Return Material Authorization (RMA) Number. If you do not have an account, send an email to support@quanmax.com to apply for one.

All product(s) returned to Quanmax for service or credit must be accompanied by a Return Material Authorization (RMA) Number. Freight on all returned items must be prepaid by the customer who is responsible for any loss or damage caused by

common carrier in transit. Returns for Warranty must include a Failure Report for each unit, by serial number(s), as well as a copy of the original invoice showing the date of purchase.

To reduce risk of damage, returns of product must be in a Quanmax shipping container. If the original container has been lost or damaged, new shipping containers may be obtained from Quanmax Customer Service at a nominal cost. Quanmax owns all parts removed from repaired products. Quanmax uses new and reconditioned parts made by various manufacturers in performing warranty repairs and building replacement products. If Quanmax repairs or replaces a product, its warranty term is not extended.

Shipments not in compliance with this Limited Warranty Return Policy will not be accepted by Quanmax.

Limitation of Liability

In no event shall Quanmax be liable for any defect in hardware, software, loss, or inadequacy of data of any kind, or for any direct, indirect, incidental, or consequential damages in connection with or arising out of the performance or use of any product furnished hereunder. Quanmax's liability shall in no event exceed the purchase price of the product purchased hereunder. The foregoing limitation of liability shall be equally applicable to any service provided by Quanmax or its authorized agent.

■ Maintaining Your Computer

Environmental Factors

■ Temperature

The ambient temperature within an enclosure may be greater than room ambient temperature. Installation in an enclosure should be such that the amount of air flow required for safe operation is not compromised.

Consideration should be given to the maximum rated ambient temperature. Overheating can cause a variety of problems, including premature aging and failure of chips or mechanical failure of devices.

If the system has been exposed to abnormally cold temperatures, allow a two-hour warm-up period to bring it up to normal operating temperature before turning it on. Failure to do so may cause damage to internal components, particularly the hard disk drive.

■ Humidity

High-humidity can cause moisture to enter and accumulate in the system. This moisture can cause corrosion of internal components and degrade such properties as electrical resistance and thermal conductivity. Extreme moisture buildup inside the system can result in electrical shorts, which can cause serious damage to the system.

Buildings in which climate is controlled usually maintain an acceptable level of humidity for system equipment. However, if a system is located in an unusually humid location, a dehumidifier can be used to maintain the humidity within an acceptable range. Refer to the “Specifications” section of this user’s guide for the operating and storage humidity specifications.

■ **Altitude**

Operating a system at a high altitude (low pressure) reduces the efficiency of the cooling fans to cool the system. This can cause electrical problems related to arcing and corona effects. This condition can also cause sealed components with internal pressure, such as electrolytic capacitors, to fail or perform at reduced efficiency.

Power Protection

The greatest threats to a system’s supply of power are power loss, power spikes, and power surges caused by electrical storms, which interrupt system operation and/or damage system components. To protect your system, always properly ground power cables and one of the following devices.

■ **Surge Protector**

Surge protectors are available in a variety of types and usually provide a level of protection proportional with the cost of the device. Surge protectors prevent voltage spikes from entering a system through the AC power cord. Surge protectors, however, do not offer protection against brownouts, which occur when the voltage drops more than 20 percent below the normal AC line voltage level.

■ **Line Conditioner**

Line conditioners go beyond the over voltage protection of surge protectors. Line conditioners keep a system’s AC power source voltage at a fairly constant level and, therefore, can handle brownouts. Because of this added protection, line conditioners cost more than surge protectors. However, line conditioners cannot protect against a complete loss of power.

■ Uninterruptible Power Supply

Uninterruptible power supply (UPS) systems offer the most complete protection against variations on power because they use battery power to keep the server running when AC power is lost. The battery is charged by the AC power while it is available, so when AC power is lost, the battery can provide power to the system for a limited amount of time, depending on the UPS system.

UPS systems range in price from a few hundred dollars to several thousand dollars, with the more expensive units allowing you to run larger systems for a longer period of time when AC power is lost. UPS systems that provide only 5 minutes of battery power let you conduct an orderly shutdown of the system, but are not intended to provide continued operation. Surge protectors should be used with all UPS systems, and the UPS system should be Underwriters Laboratories (UL) safety approved.

CAUTION



RISK OF EXPLOSION IF BATTERY IS REPLACED BY AN INCORRECT TYPE.
DISPOSE OF USED BATTERIES ACCORDING TO THE INSTRUCTIONS

Chapter 1

Introduction

■ Overview

The KPC-1530/1730 Panel PCs is combining the latest Intel 45nm Intel® Atom™ processor with the high integration of the Intel® 945GSE/ ICH7-M chipset for a wide range of industrial applications. Storage includes a 2.5" SATA hard drive or a solid-state drive (SSD), and slim optical drive. Supported interfaces include a GbE LAN, HD audio, 4x serial ports, USB 2.0 ports, PCI slot, and Mini PCI slot, thus easily meeting a broad range of customer requirements. The KPC series provide a compact, high performance human-machine interface, with optimal shock, vibration and temperature resistance for tough industrial demands.

Check list

1. Take out the KPC-1530/1730 from the carton box, check if the unit is properly secure in the plastic bag.
2. Check the contents of the carton box:
 - 1x Panel PC
 - 1x Panel Mounting Kits (with screw bag)
 - 1x Drivers/ Manual CD
 - 1x Quick Installation Guide
 - 1x Power Cord (optional)
 - 1x Wall Mounting Kits (optional)
 - 1x DC Power Adapter (optional)
 - 1x Wi-Fi antenna (optional)

Features

- 15"/17" TFT LCD Display with Resistive 5-wire TouchScreen
- Intel® Atom™ Processor N270
- Intel® 945GSE / ICH7-M
- IP65 approved front bezel
- 1x PCI Slot and 1x Mini PCI Slot Expansion
- 1x GbE, 4x COMs, 4x USB ports, VGA, HD Audio

■ Product Specifications

	KPC-1530	KPC-1730
System		
CPU	Intel® Atom™ N270	Intel® Atom™ N270
Chipset	Intel® 945GSE + ICH7-M	Intel® 945GSE + ICH7-M
Memory	1x DDR2 400/533 SO-DIMM Socket, up to 2G	1x DDR2 400/533 SO-DIMM Socket, up to 2G
Internal Storage	1x 2.5" SATA HDD or 1x SSD 1x Slim DVD-ROM	1x 2.5" SATA HDD or 1x SSD 1x Slim DVD-ROM
Expansion slots	1x PCI slot, 1x Mini PCI slot	1x PCI slot, 1x Mini PCI slot
Cooling	Fanless	Fanless
Material	Aluminum front bezel & SECC chassis	Aluminum front bezel & SECC chassis
I/Os	1x GbE, RJ-45 4x USB 2.0 1x VGA (DB-15) 4x COMs with 5V/12V Power Selection (COM1 RS-232/422/485, COM2/3/4 RS-232) 1x PS/2 Keyboard Connector 1x PS/2 Mouse Connector 1x Power On/Off Switch 1x Power Connector Mic-in, Line-in, Line-out	1x GbE, RJ-45 4x USB 2.0 1x VGA 4x COMs with 5V/12V Power Selection (COM1 RS-232/422/485, COM2/3/4 RS-232) 1x PS/2 Keyboard Connector 1x PS/2 Mouse Connector 1x Power On/Off Switch 1x Power Connector Mic-in, Line-in, Line-out
LCD Display		
Display type & size	15" TFT LCD	17" TFT LCD
Brightness	250 cd/m ²	350 cd/m ²
Resolution	XGA (1024 x 768)	SXGA (1280 x 1024)
Touch Screen	5-wire Resistive Type	5-wire Resistive Type
Wireless LAN	Wireless LAN 802.11b/g (optional)	
Environmental Specification		
Temperature	Operating: 0°C to 60°C (CF, SSD), 0°C to 50°C (2.5" HDD) Storage: 0°C to 70°C, 10%-85% rel. hum., non-condensing	
Size and weight		
Dimensions	410 x 315 x 82 mm (W x H x D)	442 x 354 x 91 mm (W x H x D)
Weight	6.4 kg	8.5 kg
Power Input	AC 100-240V(Optional DC-12V or DC-24V)	
Mounting Type	VESA, Panel Mount	
Compliant	CE, FCC Class A, IP65 front bezel	

Table 1 Specifications

■ Mechanical Layout

Front and Side Panel

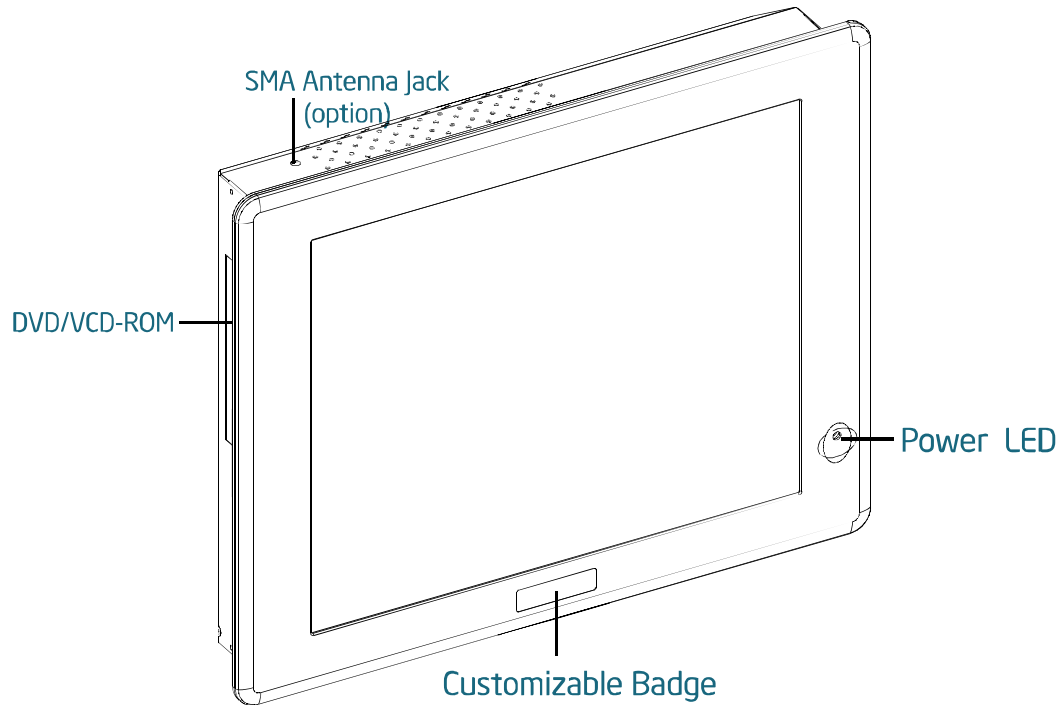

Figure 1 Mechanical Layout - Front and Side



WARNING

Be sure not to block any air vents on the computer. Blocked air vents can cause thermal problems.

I/O Panel

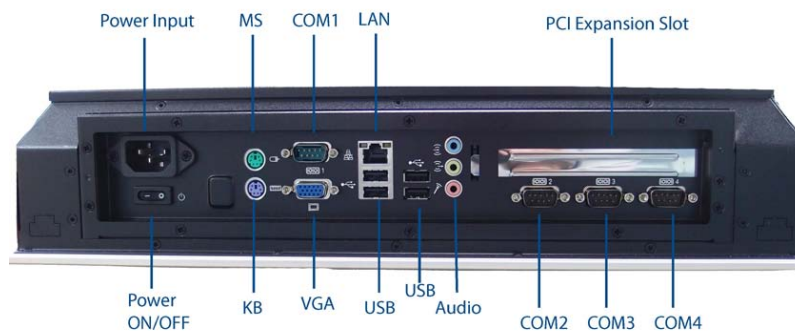
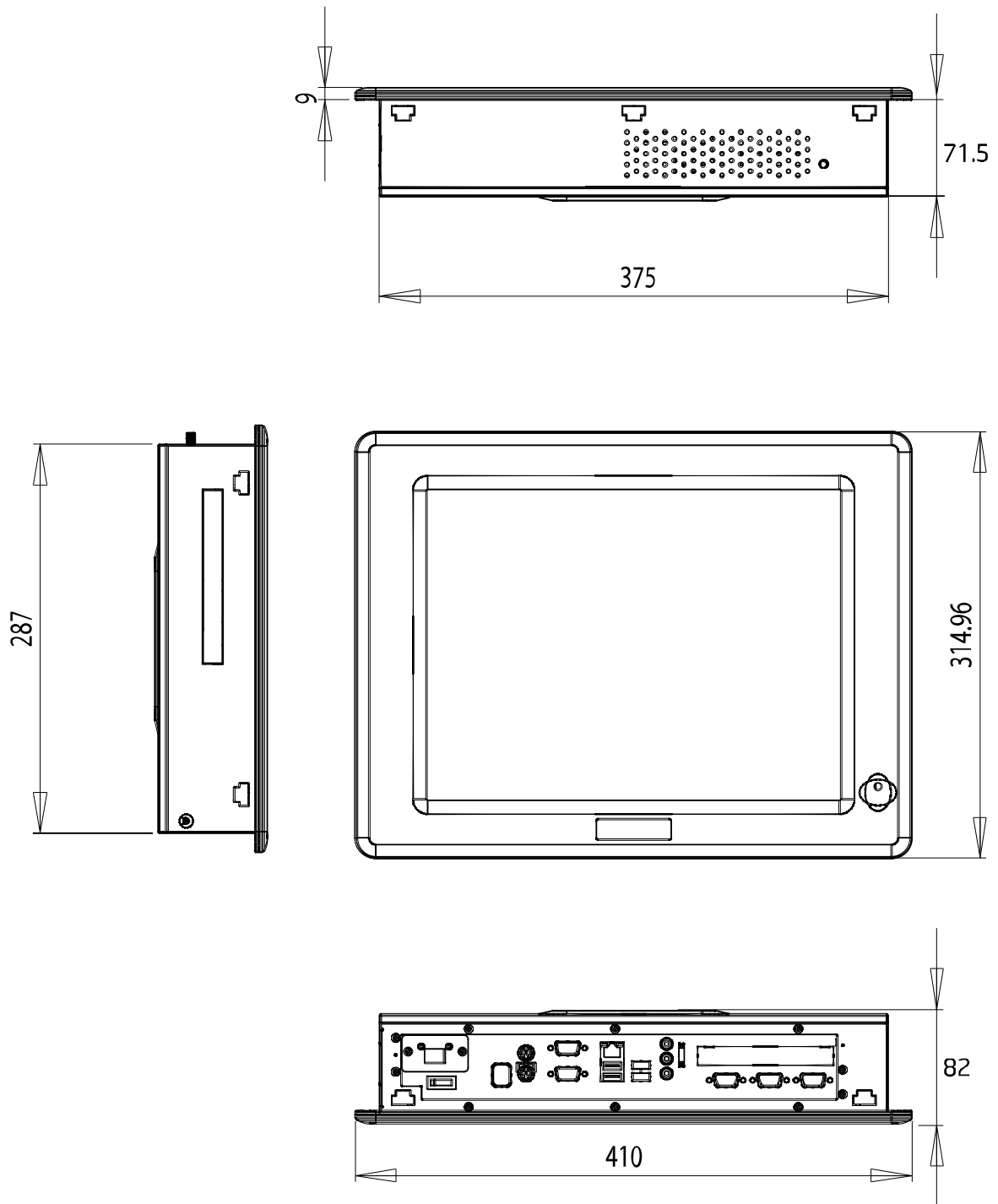

Figure 2 Mechanical Layout - I/O Panel

Mechanical Dimensions



Dimensions in Millimeters

Figure 3 Mechanical Dimensions (KPC-1530)

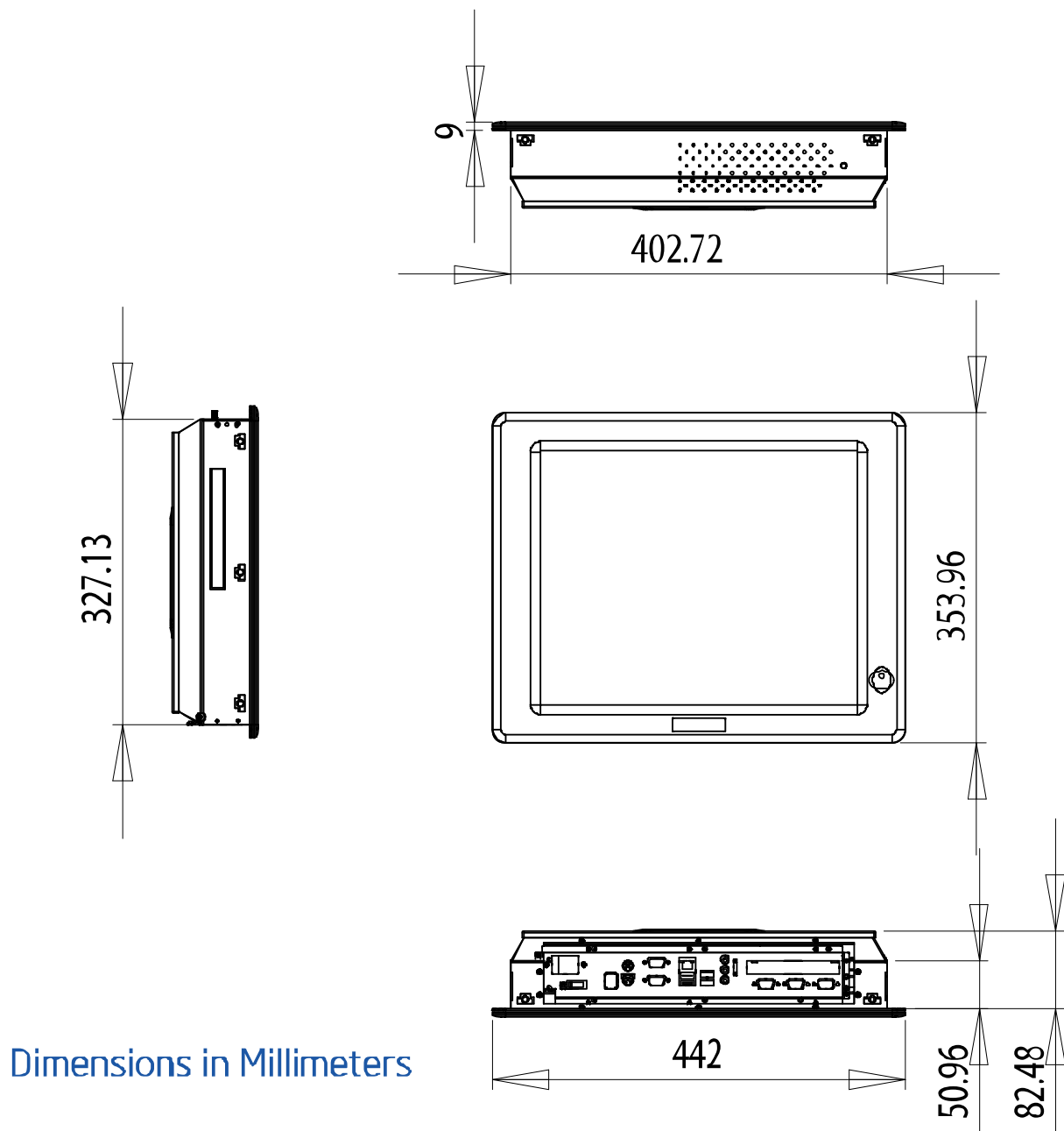

Figure 4 Mechanical Dimensions (KPC-1730)

Chapter 2

Assembly/Disassembly

■ Accessing Internal Components

WARNING



Before opening your system, make sure to turn it off and disconnect the power sources to prevent electric shock or system damage. And wait 3 to 5 minutes to let the computer cool before removing the computer cover.

Follow the procedure described below to access the system's internal components.

- 1) Place the system front-side-down on a soft material to prevent marking or scratching of the front panel. Remove the screws securing the rear panel of the chassis as shown.

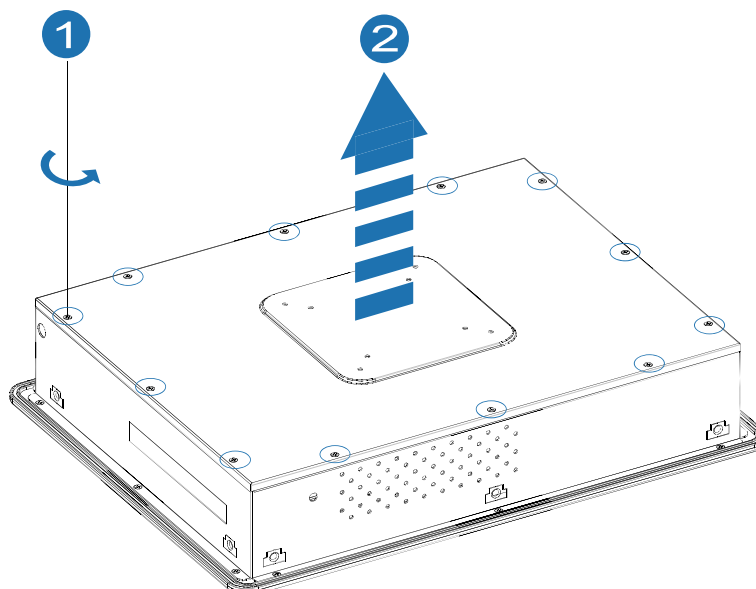

Figure 5 Removing the rear cover

- 2) Remove the rear cover. Note the locations of the internal components of the system.

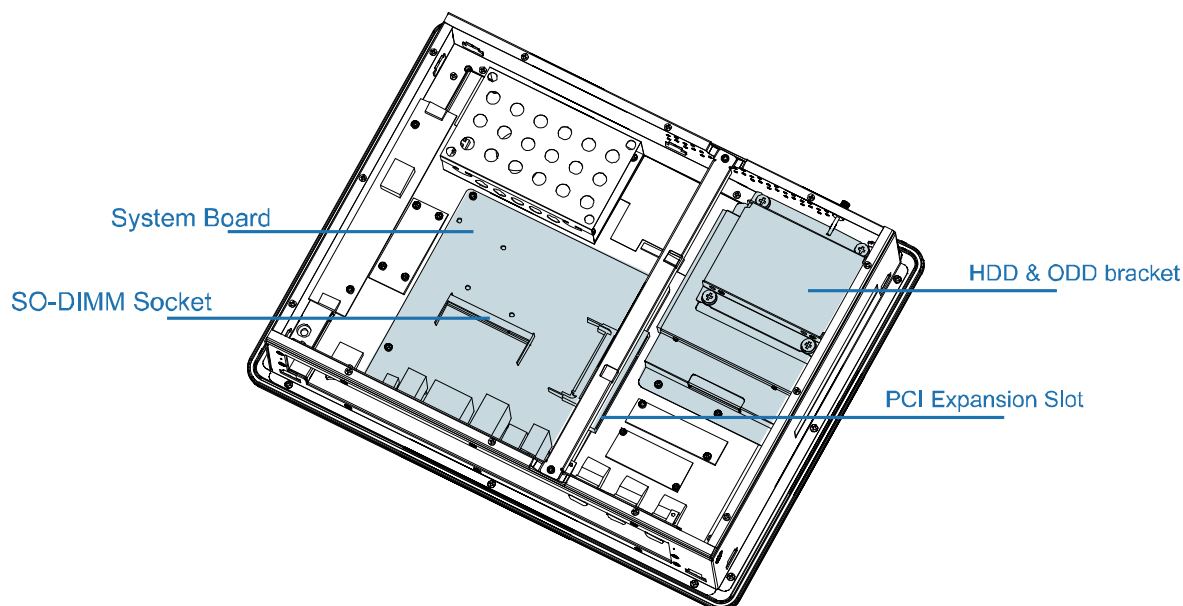

Figure 6 Mechanical Internal Layout

■ Memory Module Installation

Carefully follow the steps below in order to install the DIMMs:

1. To avoid generating static electricity and damaging the SO-DIMM, ground yourself by touching a grounded metal surface or use a ground strap before you touch the SO-DIMM.
2. Do not touch the connectors of the SO-DIMM. Dirt or other residue may cause a malfunction.
3. To make sure the correct DDR2 SO-DIMM notches should match with the DDR2 SO-DIMM.
4. Hold the SO-DIMM with its notch aligned with the memory socket of the board and insert it at a 30-degree angle into the socket.

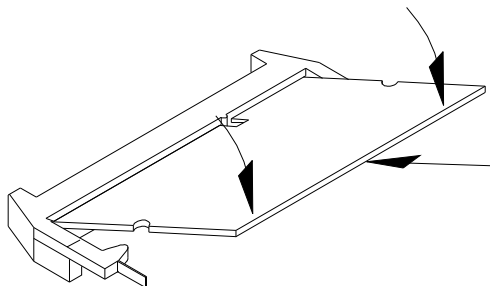

Figure 7 Align the SO-DIMM Memory Module with the onboard socket

5. Fully insert the module into the socket until a “click” is heard.
6. Press down on the SO-DIMM so that the tabs of the socket lock on both sides of the module

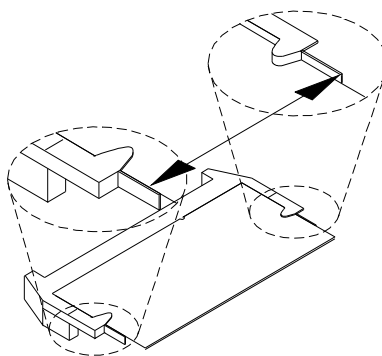

Figure 8 Press down on the SO-DIMM Memory Module to lock it in place

Removing a DIMM:

To remove the SO-DIMM, use your fingers or a small screwdriver to carefully push away the tabs that secure either side of the SO-DIMM. Lift it out of the socket. Make sure you store the SO-DIMM in an anti-static bag. The socket must be populated with memory modules of the same size and manufacturer.

■ Installation PCI Card

NOTE



When adding or removing expansion cards, make sure that you unplug the power supply first. Meanwhile, read the documentation for the expansion card to configure any necessary hardware or software settings for the expansion card, such as jumpers, switches or BIOS configuration.

The product provides space for a half-length PCI expansion card. Before installing your card, make sure it meets the following height restrictions.

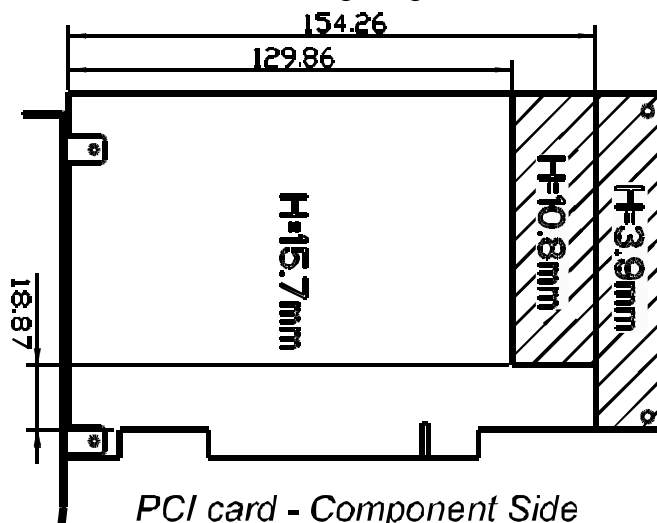

PCI card - Component Side

Figure 9 PCI card height restrictions

Follow the procedure described below to install a PCI card.

1. Remove the PCI raiser card holder (1) and PCI slot cover (2) by loosening the retaining screw as shown.

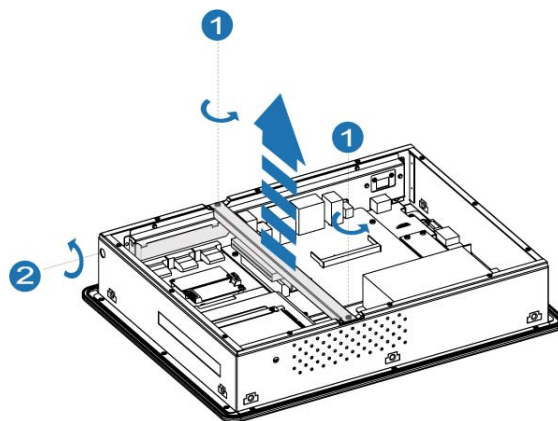

2. Fully insert the PCI card into the PCI raiser card

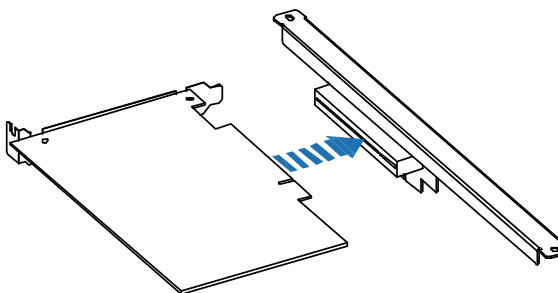

3. Replace PCI raiser card holder and secure with the retaining screw.

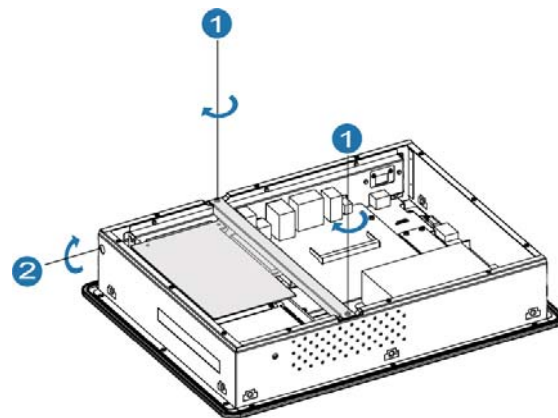

■ HDD & ODD Installation

Step 1

Remove the pre-cut bracket opening of ODD and the PCI raiser card holder.

Loosen the 4 screws and take off the ODD bracket from the system.

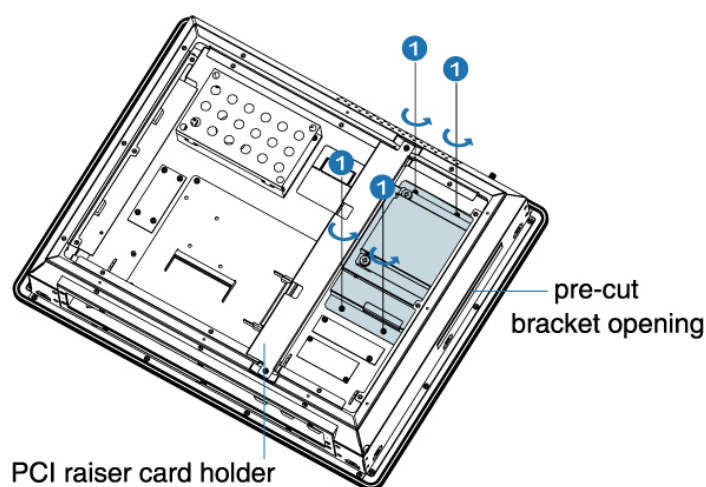

Step 2 & 3

Secure the hard drive to the HDD bracket using the short screws then secure HDD bracket to the ODD bracket using the anti-vibration screws.

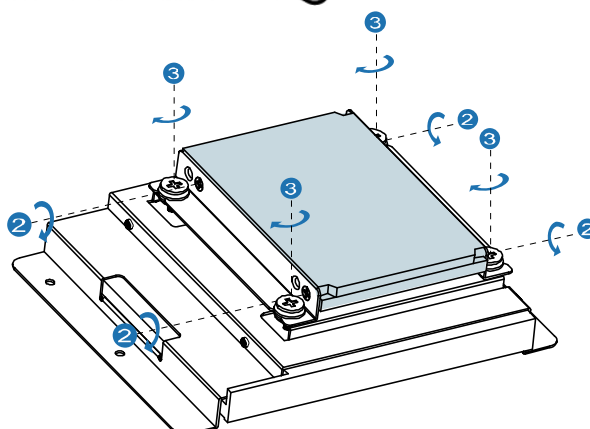

Step 4

Secure the ODD to the ODD bracket using the 4 short screws provided.

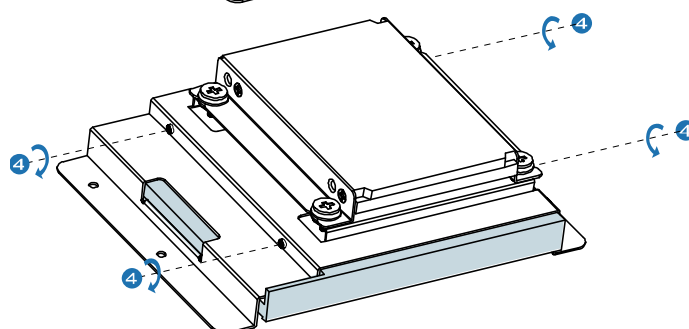

Step 5

Secure the whole bracket to the chassis and connecting the data & power cables.

Figure 10 HDD & ODD Installation

NOTE



Above procedure is for KPC-1730 only. If you want to install HDD & ODD in KPC-1530, you have to secure ODD to the ODD bracket and secure the ODD bracket to the chassis first. Then secure HDD to the HDD bracket and secure the HDD bracket to the ODD bracket.

■ VESA Mounting

The product comes with VESA FDMI 75/100 standard mounting holes as shown below. Use 4 screws with the appropriate length for your mounting bracket.

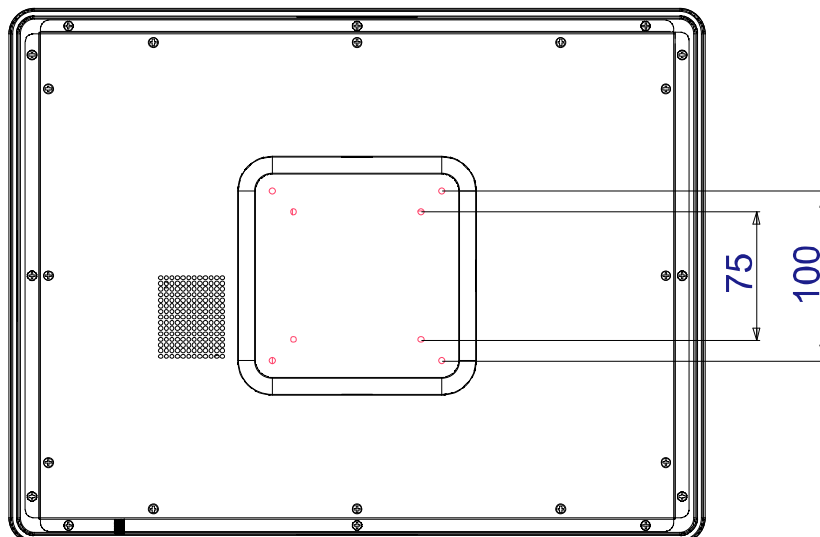

Figure 11 Mounting hole locations

■ Wall Mounting

- Below are the demonstrations of how to use Quanmax wall-mount kits

Step1

Secure the VESA kit to the panel PC using the 4 screws.

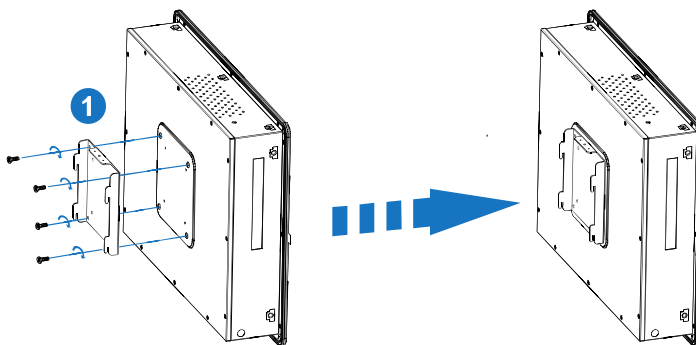

Step2

Install the wall-mount kit to the proper place of the wall by using the 6 screws.

Step3

Attach the panel PC to the wall-mount kit which has been well fixed on the wall.

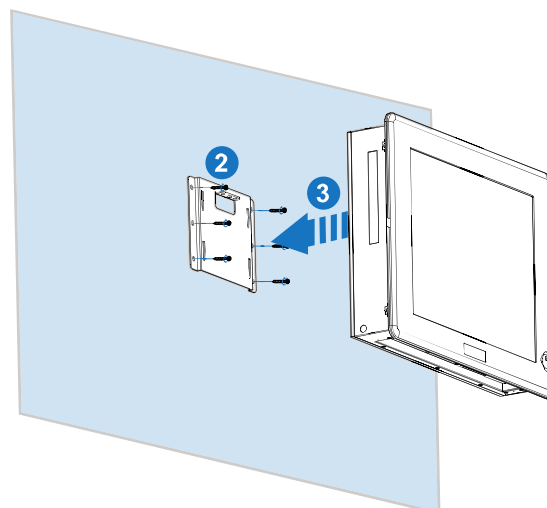

Step4

Secure the wall-mount kit and panel PC with screw by using Phillips Screwdriver

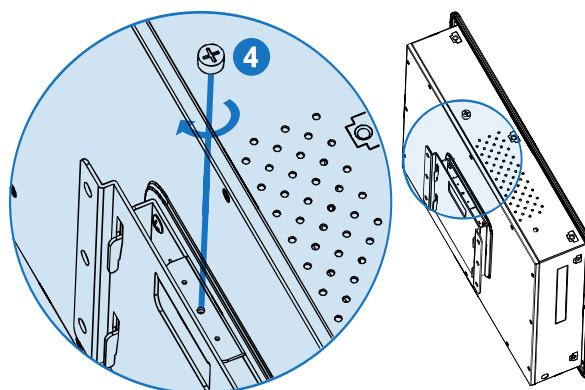

Figure 12 Wall Mounting Demonstrations

■ Panel Mounting

The Panel PC can be panel mounted and comes with brackets and screws for this purpose. The required cutout for panel mounting and maximum panel thickness is shown below.

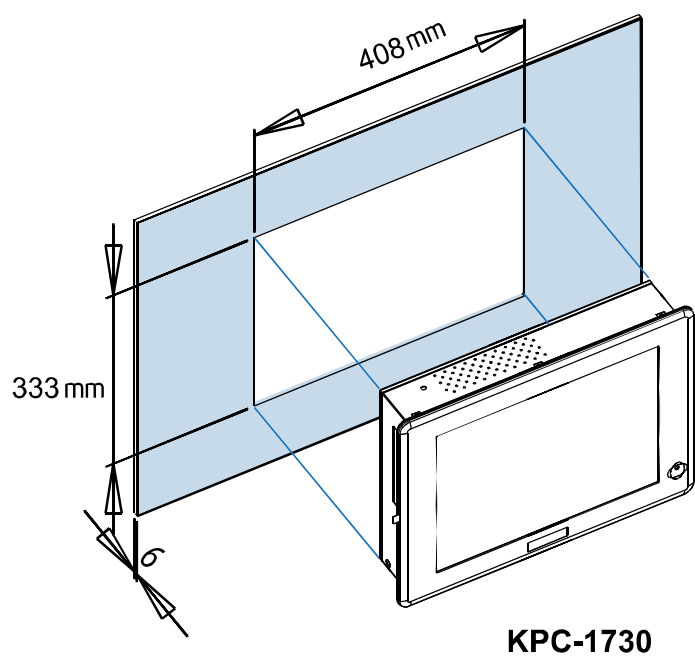
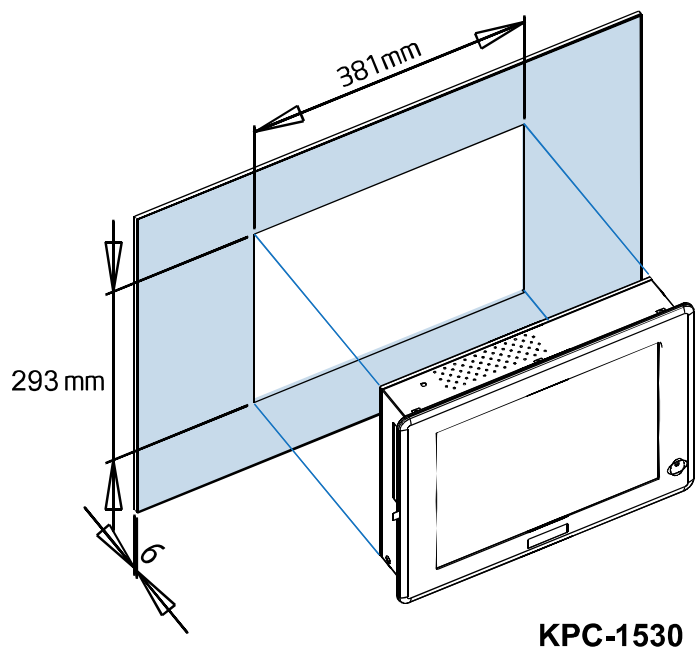

Figure 13 Panel Mount Cut-out hole and maximum panel thickness

■ Below are the demonstrations of how to do panel mounting.

Step1

Remove the pre-cut Bracket Opening Covers by firmly inserting a flathead screwdriver and bending them back and forth until they break free from the chassis.

“KPC-1530: 9 Bracket Opening Covers”

“KPC-1730: 10 Bracket Opening Covers”

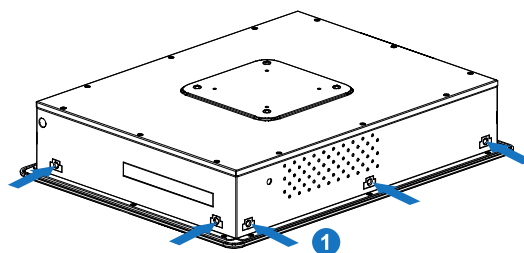

Step2

Install the Panel Mount Seal on the inside edge of the Panel PC

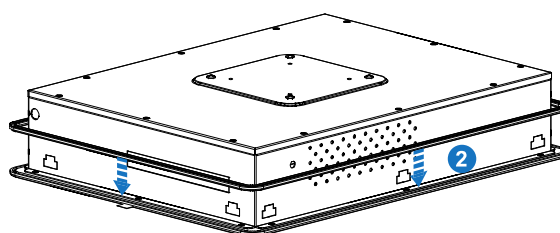

Step3

Insert a Panel Mount Bracket into a bracket opening as shown.

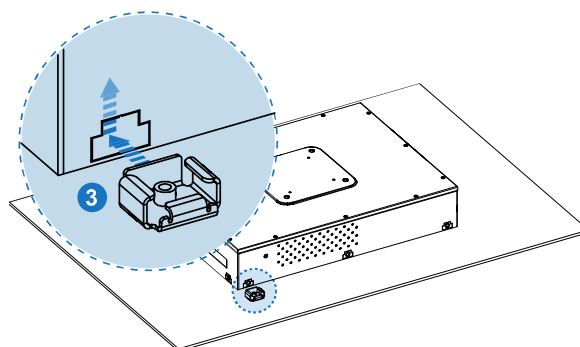

Step4

Secure the chassis to the panel by tightening the screw provided against the panel. Repeat for the remaining brackets.

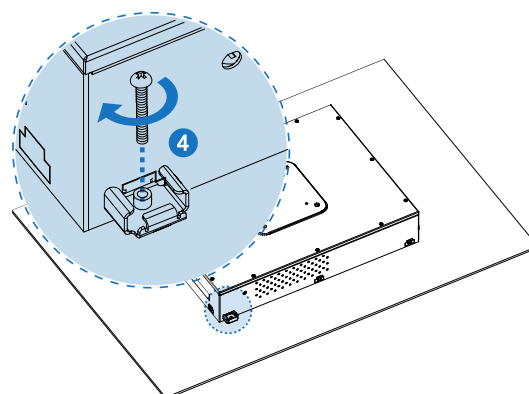

Figure 14 Panel Mounting

Chapter 3

Getting Started

■ Power Connection

CAUTION



Use the power cord suitable for the power supply in your country. Do not remove or alter the grounding prong on the power cord. In situations where a two-slot receptacle is present, have it replaced with a properly grounded three-prong grounding type receptacle.

AC Power

1. Connect the supplied AC power cord to the system AC power inlet on the I/O panel of the system.
2. Connect the other end of the AC power cord to a corresponding outlet.

DC Power

The product comes with a two pin header that carries 12VDC external power input.

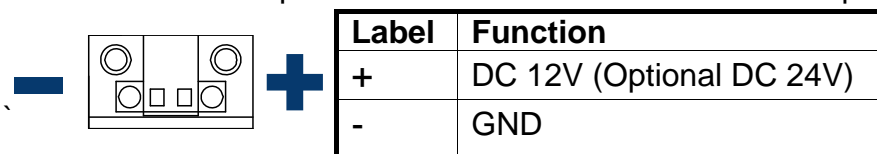

1. Make sure the power distribution to the DC power feed wires is disconnected.
2. Loosen the screws securing the terminal block to the DC inlet as shown and remove it from the chassis.

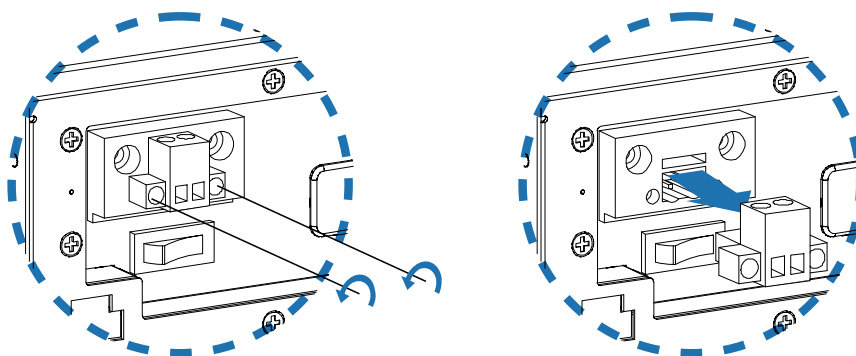

3. Remove just enough insulator material from the ends of the wires to allow a proper electrical connection to the terminal block.
4. Insert the power feed wires into the terminal block and tighten the compression clamps as shown.

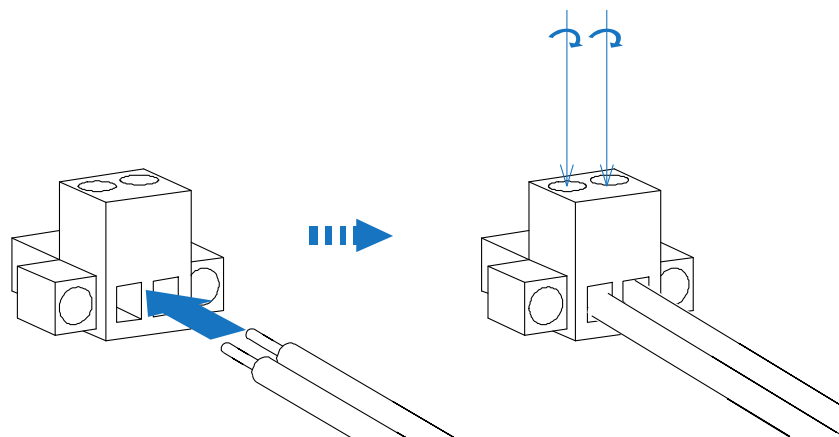

5. Insert the terminal block into the DC inlet in the chassis and secure by tightening the screws loosened in Step 2.

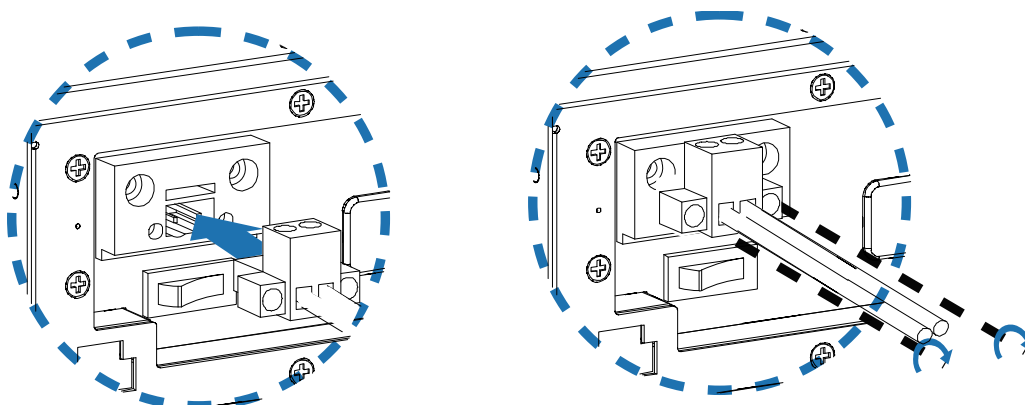

6. Connect the power distribution to the DC power feed wires.
7. Press the power button to turn it on.

■ Operating System and Drivers

If your product does not come with an operating system pre-installed, you will need to install an operating system and the necessary drivers to operate it. After you have finished assembling your system and connected the appropriate power source, power it up using the power supply and install the desired operating system. You can download the drivers for the product from the Quanmax website at www.quanmax.com and install as instructed there. For other operating systems, please contact Quanmax.

Chapter 4

Maintenance and Prevention

Your KPC-1530/1730 system requires minimal maintenance and care to keep it operating correctly.

- Occasionally wipe the system with a soft dry cloth.
- You should only remove persistent dirt by use of a soft, slightly damp cloth (use only a mild detergent).
- Make sure the ventilation holes are clear of debris.

CAUTION



Do **NOT** do any of the following:

- Allow water to enter the computer
 - Use a heavily dampened cloth
 - Spray water directly inside of computer
-

Chapter 5

Interface & Jumper Setting

External Connectors

Table 2 AUDIO, 3-Port Audio phone jack

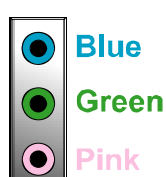

	Signal Name
BLUE	LINE IN
GREEN	LINE OUT
PINK	MIC IN

Table 3 USB, USB2.0 Type A Connector

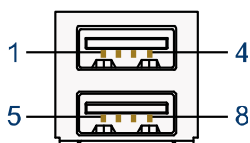

Pin	Signal Name	Pin	Signal Name
1	+5V	5	+5V
2	USBx-	6	USBx-
3	USBx+	7	USBx+
4	GND	8	GND

Table 4 LAN, Ethernet RJ-45 Connector

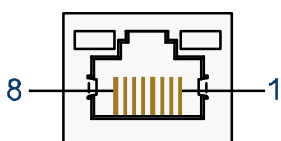

Pin	Signal	Pin	Signal
1	Tx+	5	NC
2	Tx-	6	Rx-
3	Rx+	7	NC
4	NC	8	NC

LAN LED Status

Status	Led	Orange / Green	Yellow
No link		Off	Off
10M link		Off	Off
10M active		Off	Blink
100M link		Green on	Off
100M active		Green on	Blink
1000M link		Orange on	Off
1000M active		Orange on	Blink

Table 5 COM1 RS-232/422/485 Connector (DB9)_

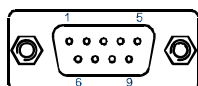

Pin	RS232	RS422	RS485 Half Duplex
1	DCD, Data carrier detect	TX-	DATA-
2	RXD, Receive data	RX+	N/A
3	TXD, Transmit data	TX+	DATA+
4	DTR, Data terminal ready	RX-	N/A
5	GND, ground	GND	GND
6	DSR, Data set ready	N/A	N/A
7	RTS, Request to send	N/A	N/A
8	CTS, Clear to send	N/A	N/A
9	RI, Ring indicator (+5V / +12V *)	N/A	N/A

* Voltage can be selected JP4.

COM1 Function Type RS232/422/485 can be selected from BIOS setting.

Table 6 COM2-4 RS-232 Connector (DB9)

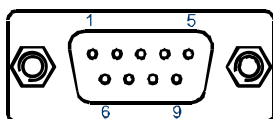

Pin	Signal
1	+5V / +12V / DCD, Data carrier detect Note : Selected by JP5-7
2	RXD, Receive data
3	DTR, Data terminal ready
4	GND, ground
5	TXD, Transmit data
6	DSR, Data set ready
7	RTS, Request to send
8	CTS, Clear to send
9	+5V / +12V / RI, Ring indicator Note : Selected by JP5-7

Table 7 VGA Connector (DB15)

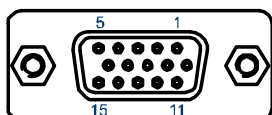

Signal Name	Pin	Pin	Signal Name
Red	1	2	Green
Blue	3	4	NC
GND	5	6	GND
GND	7	8	GND
VCC	9	10	GND
NC	11	12	DDC2B data
HSYNC	13	14	VSYNC
DDC2B clock	15		

Table 8 CN 10, PS/2 KB/MS Connector

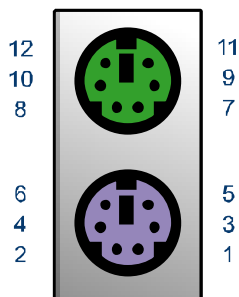

Pin	Signal	Function
1	KBDAT	Keyboard Data
2	NC	No Connect
3	GND	Ground
4	KB5V	+5VSB Power Source
5	KBCLK	Keyboard Clock
6	NC	No Connect
7	MSDAT	Mouse Data
8	NC	No Connect
9	GND	Ground
10	KB5V	+5VSB Power Source
11	MSCLK	Mouse Clock
12	NC	No Connect

■ Jumper Setting

Table 9 JP4, COM1 Signal / Power Selection

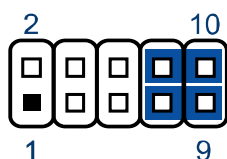

Jumper	Setting	Function
1	1-3 Short	Pin 1 of COM1 = +12V
	3-5 Short	Pin 1 of COM1 = +5V
	5-7 Short	Pin 1 of COM1 = +5V
	7-9 Short	Pin 1 of COM1 = DCD@RS232, TX-@RS422, DATA-@RS485 (Default)
2	2-4 Short	Pin 9 of COM1 = +12V
	4-6 Short	Pin 9 of COM1 = +5V
	6-8 Short	Pin 9 of COM1 = +5V
	8-10 Short	Pin 9 of COM1 = RI (Default)

Table 10 JP5/ 6/ 7, COM2/ 3/ 4 Signal / Power Selection

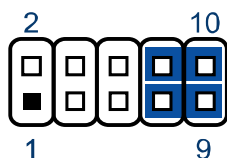

Jumper	Setting	Function
1	1-3 Short	Pin 1 of COM2/ 3/ 4 = +12V
	3-5 Short	Pin 1 of COM2/ 3/ 4 = +5V
	5-7 Short	Pin 1 of COM2/ 3/ 4 = +5V
	7-9 Short	Pin 1 of COM2/ 3/ 4 = DCD (Default)
2	2-4 Short	Pin 9 of COM2/ 3/ 4 = +12V
	4-6 Short	Pin 9 of COM2/ 3/ 4 = +5V
	6-8 Short	Pin 9 of COM2/ 3/ 4 = +5V
	8-10 Short	Pin 9 of COM2/ 3/ 4 = RI (Default)

Table 11 JP3, Clear CMOS Selection



Jumper	Status
Open	Normal Operation (Default)
Short	Clear CMOS

Figure 15 Jumper and Connector Locations

