



FEATURES

- Digital controller with auto compensation
- PMBus compatibility
- Fast transient response
- High efficiency:
93.7% @12Vin, 3.3V/25A out
- Size: 22.9x12.7x10.2mm(0.90"x0.50"x0.40")
- Surface mount
- No minimum load required
- Wide input range:8V~12.8V
- Pre-bias start up
- Output voltage programmable from 0.7Vdc to 3.3Vdc via external resistors or PMBUS command.
- Default fixed frequency operation:600kHz
- Frequency can be synchronized with an external clock
- Input UVLO,OVP, Output OVP, OTP, OCP, SCP
- Remote ON/OFF
- Multiple modules parallel operation
- ISO 9000, TL 9000, ISO 14001 certified manufacturing facility
- UL/cUL 60950-1 (US & Canada) recognized

Delphi Series DGQ25A, Non-Isolated, Digital Smart DC/DC Power Module: 8.0~12.8Vin, 0.7Vo~3.3Vo, 25A Iout

The DGQ25A, 8.0~12.8V wide input, single output, non-isolated smart power module is the latest offering from a world leader in power systems technology and manufacturing -- Delta Electronics, Inc. DGQ25A is a digital module that can achieve high efficiency, automatic compensation, fast transient response, PMBus communication and parallel operation. It can provide a programmable output voltage from 0.7V to 3.3V by using an external resistor or through PMBus command.

It provides a highly efficient, high power and current density and very cost effective power module solution. With creative design technology and optimization of component placement, these converters possess outstanding electrical and thermal performance, as well as extremely high reliability under highly stressful operating conditions.

APPLICATIONS

- Telecom / DataCom
- Distributed power architectures
- Servers and workstations
- LAN / WAN applications
- Data processing applications



Ta = 25°C, airflow rate = 200 LFM, Vin=12Vdc nominal, Io,max=25A, single module operation unless otherwise noted.

TECHNICAL SPECIFICATIONS

PARAMETER	NOTES and CONDITIONS	DGQ25A			
		Min.	Typ.	Max.	Units
ABSOLUTE MAXIMUM RATINGS					
Input Voltage (Continuous)		-0.3		16	Vdc
Operating Ambient Temperature	With appropriate air flow and derating	-40		85	°C
Storage Temperature		-40		150	°C
INPUT CHARACTERISTICS					
Operating Input Voltage		8.0	12	12.8	V
Maximum Input Current	Vin=9.6V, Vout=3.3V, Io= Io,max			9.5	A
No-Load Input Current	Vin=12V, Vout=3.3V, Io=0A			120	mA
Off Converter Input Current				20	mA
ON/OFF Control					
Logic High Voltage	Module On	2.4		4	V
Logic Low Voltage	Module Off	-0.3		0.8	V
OUTPUT CHARACTERISTICS					
Output Voltage Adjustable Range		0.7		3.3	V
Output Voltage Set Point	VIN = 12V, Load = 50%,	-1		1	%Vo,set
Line regulation	VIN = 8V~12.8V		±0.6		%Vo,set
Load regulation	Load =0~25A,		±1		%Vo,set
Output voltage tolerance	Over all rated input voltage, load, and temperature conditions to end of life	-2		2	%Vo,set
Output Voltage Ripple and Noise	20MHz bandwidth, with 500uF ceramic capacitor				
Vo=0.7V				20	mVp-p
Vo=1.2V				35	mVp-p
Vo=1.8V				35	mVp-p
Vo=3.3V				45	mVp-p
Output Current Range(Io,max)		0		25	A
DYNAMIC CHARACTERISTICS					
Dynamic Load Response	With 850uF ceramic co, Io slew rate =1A/μs, Io from 25% to 75% to 25% of Io,max				
Vo=0.7V		-15		15	% Vo,set
Vo=1.2V		-9.5		9.5	% Vo,set
Vo=1.8V		-7		7	% Vo,set
Vo=3.3V		-4.5		4.5	% Vo,set
Setting Time to 1% of Peak			30		μs
EFFICIENCY					
Vo=0.7V	Vin=12V, Io=Io,max		81.4		%
Vo=1.2V	Vin=12V, Io= Io,max		87.2		%
Vo=1.8V	Vin=12V, Io= Io,max		90.2		%
Vo=3.3V	Vin=12V, Io= Io,max		93.7		%
EXTERNAL CAPACITANCE					
Input Capacitance	External Input Capacitance is typically 70% Ta and 30% ceramic	44		2000	μF
Output Capacitance	External Output Capacitance is typically 100% ceramic, X7R,1206 case or smaller	500		2000	μF
TURN ON/OFF					
Delay time	Defined as time between enable and Vout rising to 10% of final value				
	For single module operation		4		ms
	For multiple modules parallel operation		60		ms
Output Rise Time	Defined as time between Vout at 10% of final value and Vout at 90% of final value.				
	For single module operation		4		ms
	For multiple modules parallel operation		10		ms
Turn-On Over-shoot				2	% Vo,set
Start up tuning signal spec	The controller need start-up adaptive tuning signal for auto compensation				
Duration time(single phase operation)	Time from vo reach to 100% regulation level to the end of the tuning signal		11		ms
Duration time(parallel operation)	Time from vo reach to 100% regulation level to the end of the tuning signal		17		ms
Tuning signal peak to peak amplitudes	Includes switching ripples and steady state noise, doesn't include regulation errors.				
Vo=0.7V		-2.5		2.5	% Vo,set
Vo=1.2V		-2.5		2.5	% Vo,set
Vo=1.8V		-2.5		2.5	% Vo,set
Vo=3.3V		-2		2	% Vo,set
PROTECTION					
Input Over Voltage	Hiccup mode		14		V
Input Under-Voltage Lockout					
Turn-On Voltage Threshold		7.0	7.5	8.0	V
Turn-Off Voltage Threshold		6.0	6.5	7.0	V
Output Over Voltage	Shutdown mode			130	%Vo,set
Output DC Current-Limit Inception	Hiccup mode			120	% Io,max
Over-Temperature Shutdown	Hiccup mode			120	°C
FEATURE CHARACTERISTICS					
Switching Frequency			600		kHz
Current sense accuracy	Io=10A ~25A	-2%		2%	%Io
	Io=0A~10A	-3.5%		3.5%	%Io
Number of paralleled modules				4	
Current sharing accuracy of paralleled operation		-10%		+10%	%Io
GENERAL SPECIFICATIONS					
MTBF	Vin=12V,Io=80% of Io,max, Ta=25°C	1			M hours
Weight			7.5		grams

ELECTRICAL CHARACTERISTICS CURVES(SINGLE MODULE OPERATION)

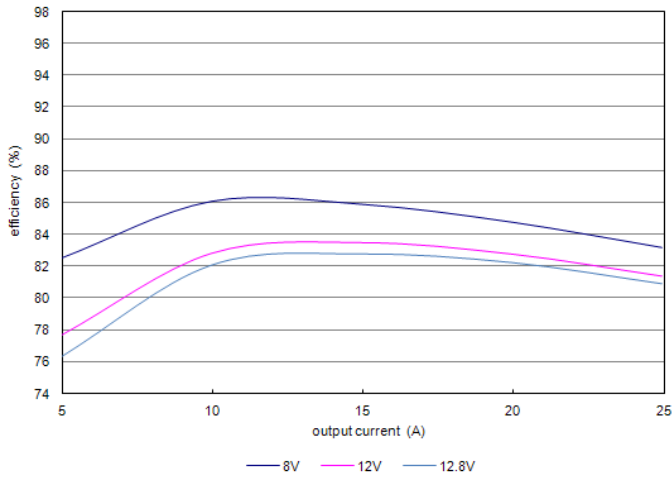

Figure 1: Converter efficiency vs. output current (0.7V output voltage)

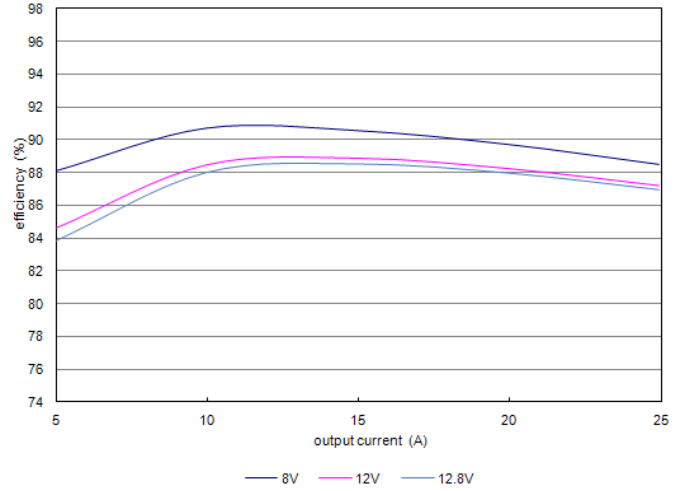

Figure 2: Converter efficiency vs. output current (1.2V output voltage)

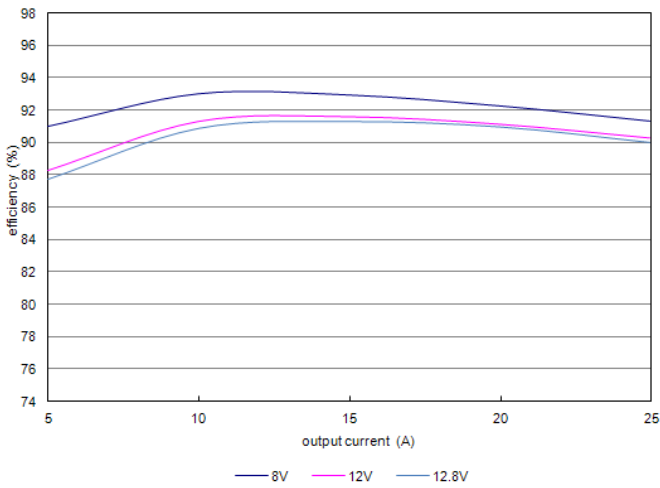

Figure 3: Converter efficiency vs. output current (1.8V output voltage)

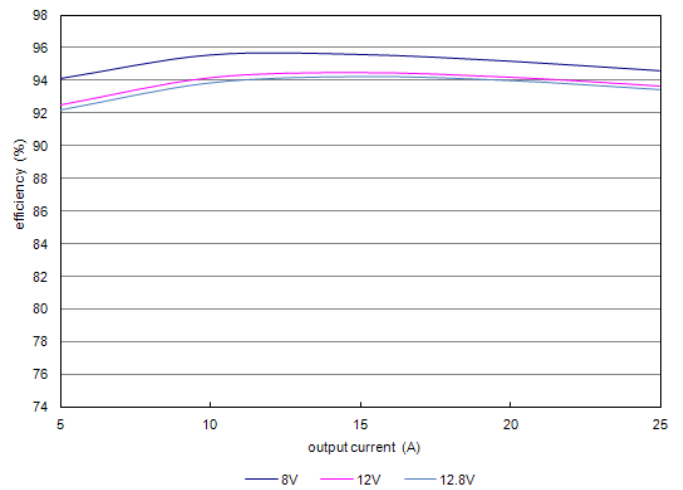

Figure 4: Converter efficiency vs. output current (3.3V output voltage)



Figure 5: Output ripple & noise at $V_{in}=12V, V_{out}=0.7V, I_{out}=25A, 2\mu S/div, 5mV/div$.

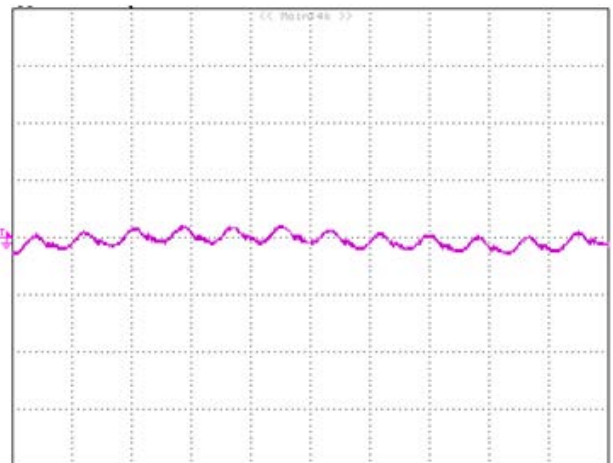

Figure 6: Output ripple & noise at $V_{in}=12V, V_{out}=1.2V, I_{out}=25A, 2\mu S/div, 10mV/div$.

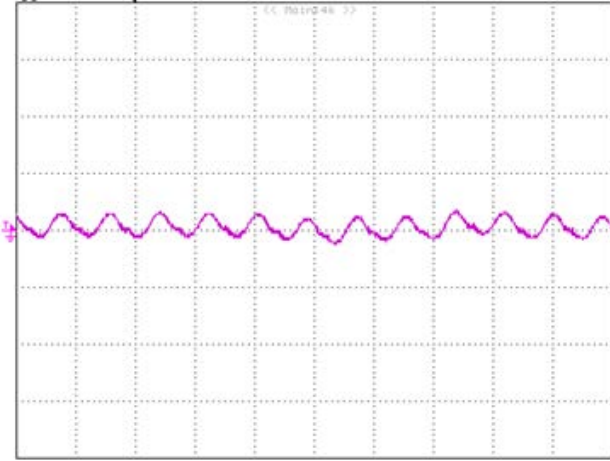

Figure 7: Output ripple & noise at $V_{in}=12V, V_{out}=1.8V, I_{out}=25A, 2\mu S/div, 10mV/div$.

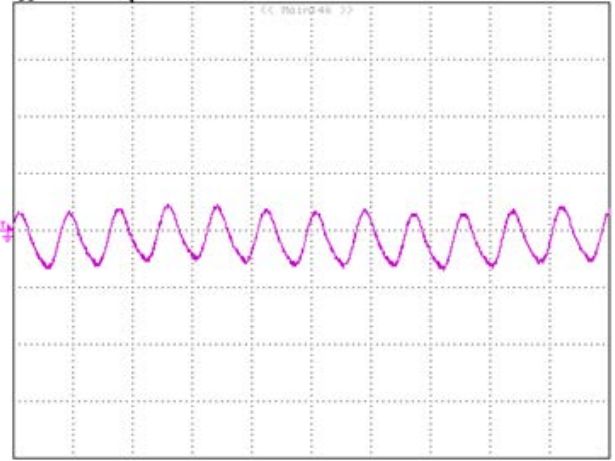

Figure 8: Output ripple & noise at $V_{in}=12V, V_{out}=3.3V, I_{out}=25A, 2\mu S/div, 10mV/div$.

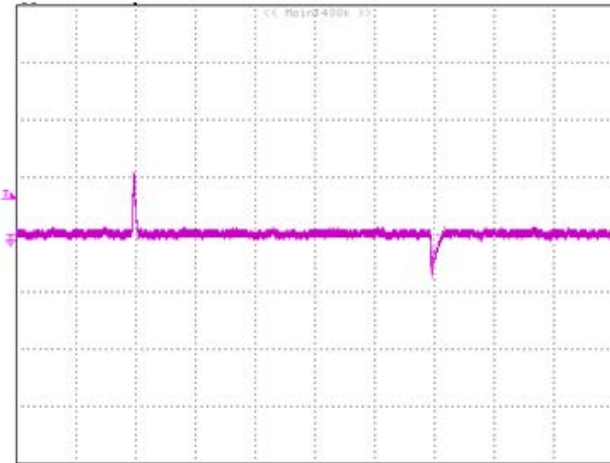

Figure 9: Output voltage response to step-change in load current (25%-75%-25% of full load at $V_{in}=12V, V_o=0.7V$; 100mV/div, 200uS/div, $di/dt=2.5A/\mu s$; 500uF ceramic C_{out})

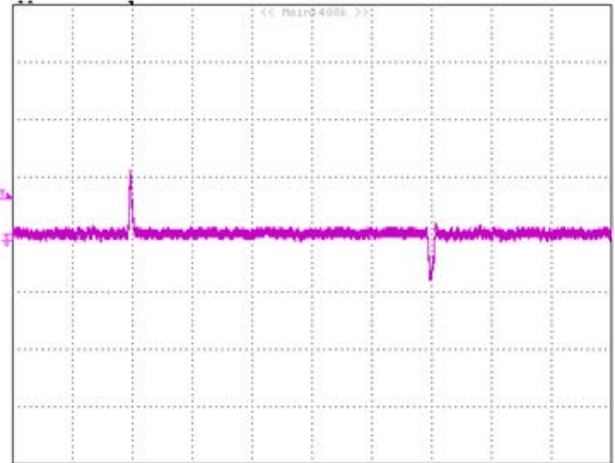

Figure 10: Output voltage response to step-change in load current (25%-75%-25% of full load at $V_{in}=12V, V_o=1.2V$; 100mV/div, 200uS/div, $di/dt=2.5A/\mu s$; 500uF ceramic C_{out})

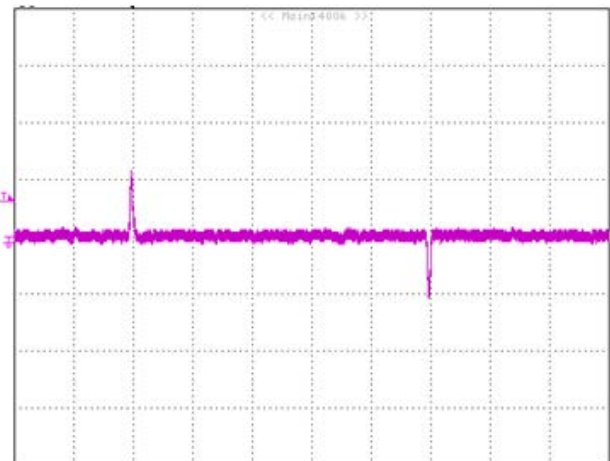

Figure 11: Output voltage response to step-change in load current (25%-75%-25% of full load at $V_{in}=12V, V_o=1.8V$; 100mV/div, 200uS/div, $di/dt=2.5A/\mu s$; 500uF ceramic C_{out})

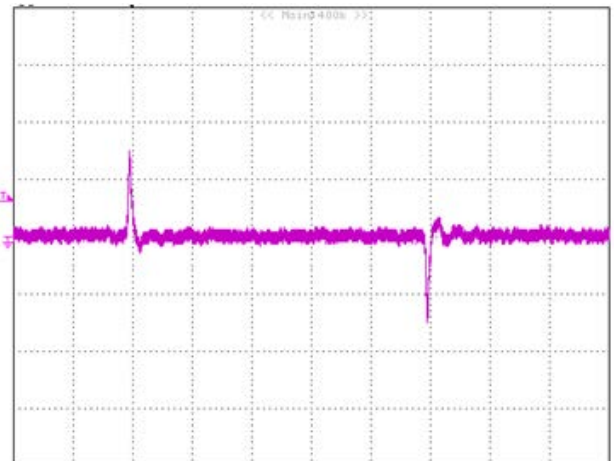

Figure 12: Output voltage response to step-change in load current (25%-75%-25% of full load at $V_{in}=12V, V_o=3.3V$; 100mV/div, 200uS/div, $di/dt=2.5A/\mu s$; 500uF ceramic C_{out})

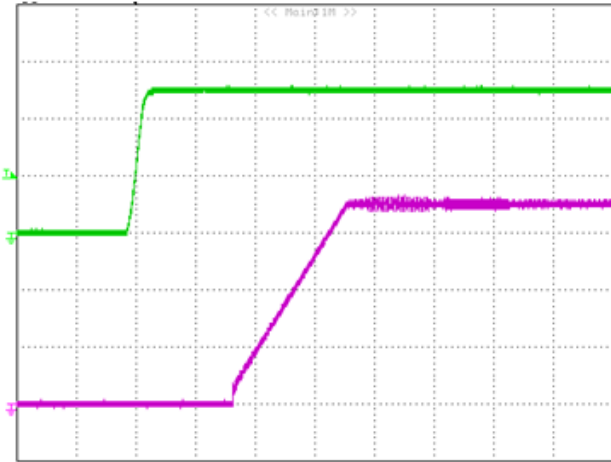

Figure 13: Turn on by enable at $V_{in}=12V$, $V_{out}=0.7V/25A$.
Top Trace: Enable, 2V/div; Bottom Trace: Vout, 0.2V/div;
Time: 2ms/div.

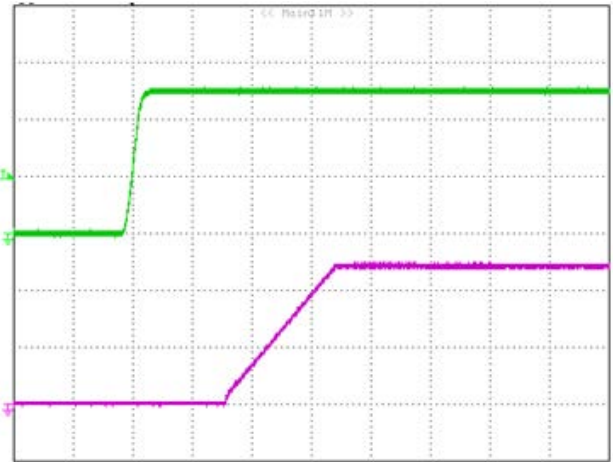

Figure 14: Turn on by enable at $V_{in}=12V$, $V_{out}=1.2V/25A$.
Top Trace: Enable, 2V/div; Bottom Trace: Vout, 0.5V/div;
Time: 2ms/div.

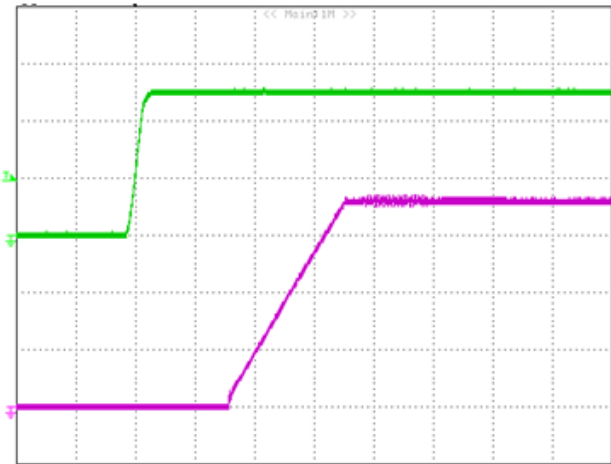

Figure 15: Turn on by enable at $V_{in}=12V$, $V_{out}=1.8V/25A$.
Top Trace: Enable, 2V/div; Bottom Trace: Vout, 0.5V/div;
Time: 2ms/div.

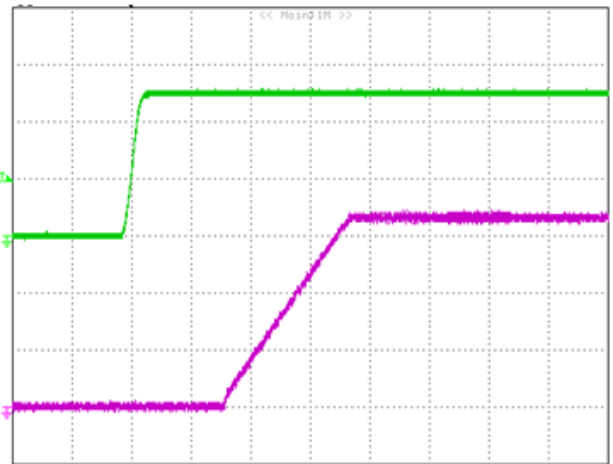

Figure 16: Turn on by enable at $V_{in}=12V$, $V_{out}=3.3V/25A$.
Top Trace: Enable, 2V/div; Bottom Trace: Vout, 1V/div;
Time: 2ms/div.

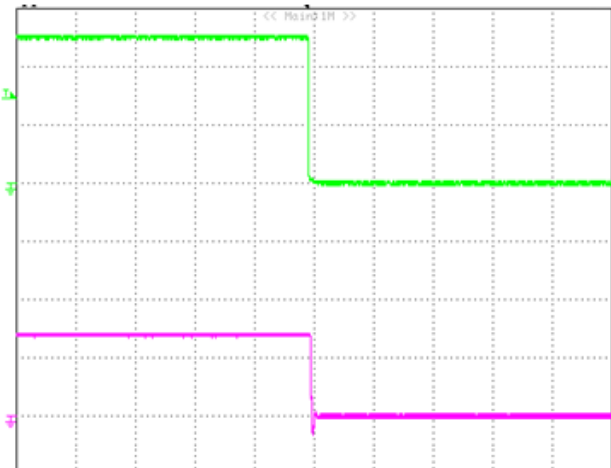

Figure 17: Turn off by enable at $V_{in}=12V$, $V_{out}=0.7V/25A$.
Top Trace: Enable, 2V/div; Bottom Trace: Vout, 0.5V/div;
Time: 2ms/div.

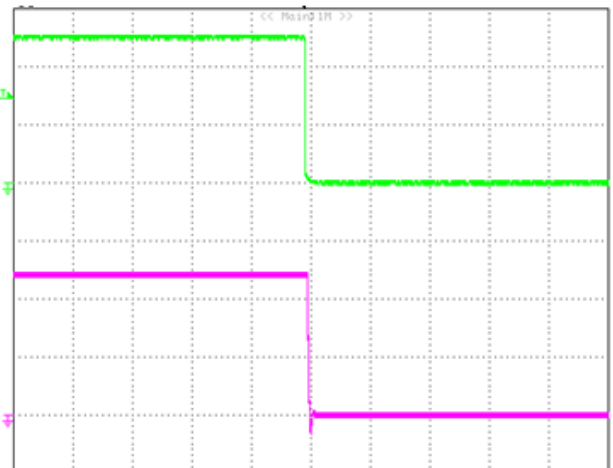

Figure 18: Turn off by enable at $V_{in}=12V$, $V_{out}=1.2V/25A$.
Top Trace: Enable, 2V/div; Bottom Trace: Vout, 0.5V/div;
Time: 2ms/div.

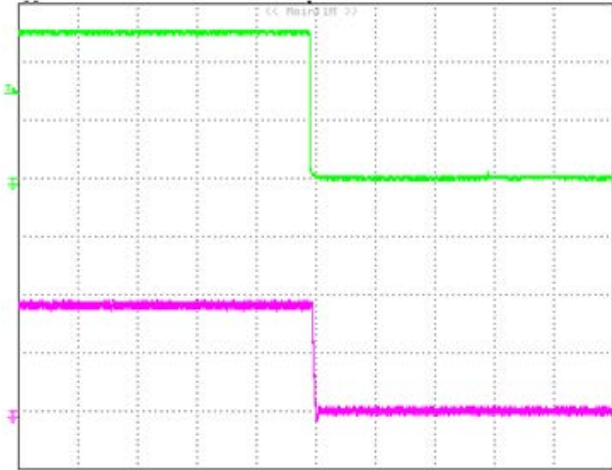

Figure 19: Turn off by enable at $V_{in}=12V$, $V_{out}=1.8V/25A$.
Top Trace: Enable, 2V/div; Bottom Trace: Vout, 1V/div;
Time: 2ms/div.

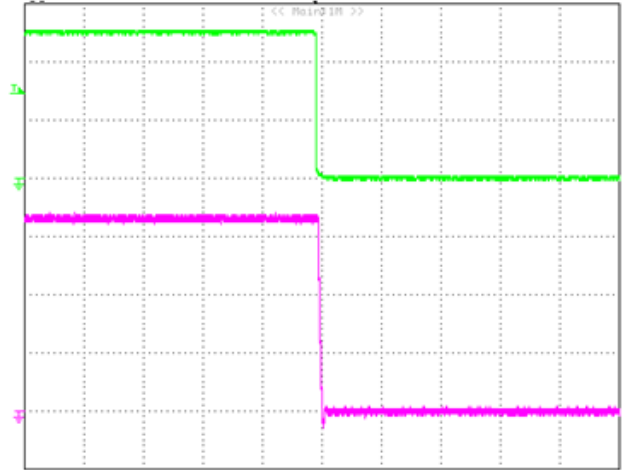

Figure 20: Turn off by enable at $V_{in}=12V$, $V_{out}=3.3V/25A$.
Top Trace: Enable, 2V/div; Bottom Trace: Vout, 1V/div;
Time: 2ms/div.

ELECTRICAL CHARACTERISTICS CURVES(4 MODULES PARALLEL OPERATION)

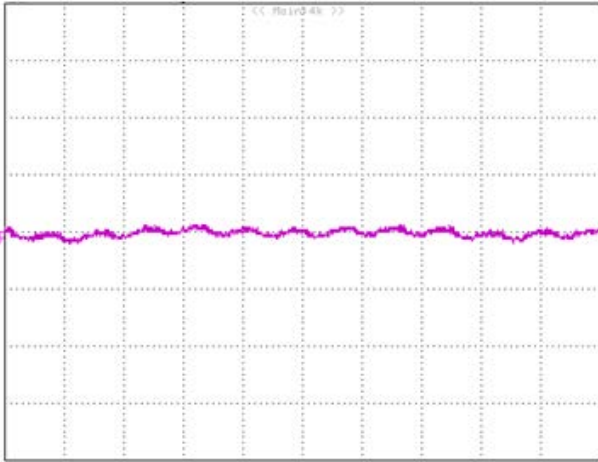

Figure 21: Output ripple & noise at $V_{in}=12V, V_{out}=0.7V, I_{out}=100A, 2\mu S/div, 5mV/div$.

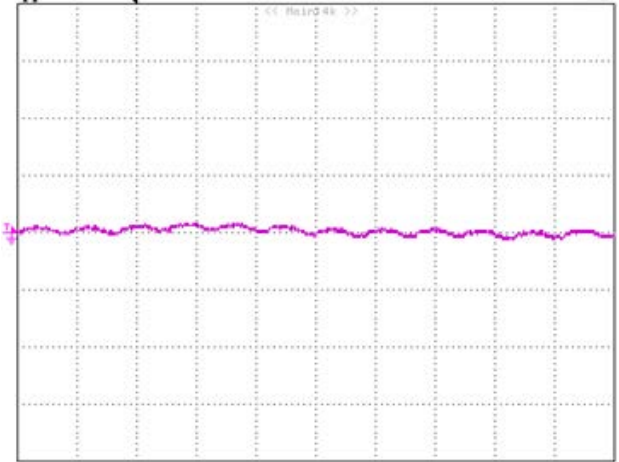

Figure 22: Output ripple & noise at $V_{in}=12V, V_{out}=1.2V, I_{out}=100A, 2\mu S/div, 10mV/div$.

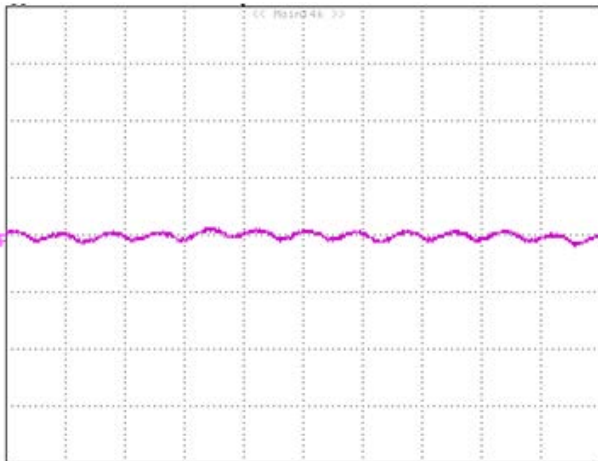

Figure 23: Output ripple & noise at $V_{in}=12V, V_{out}=1.8V, I_{out}=100A, 2\mu S/div, 10mV/div$.

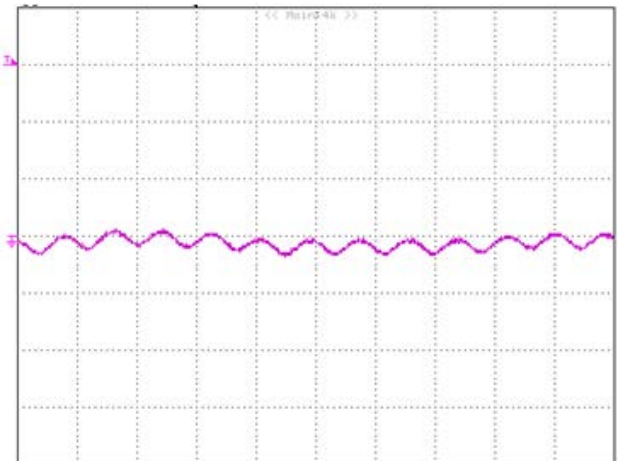

Figure 24: Output ripple & noise at $V_{in}=12V, V_{out}=3.3V, I_{out}=100A, 2\mu S/div, 10mV/div$.

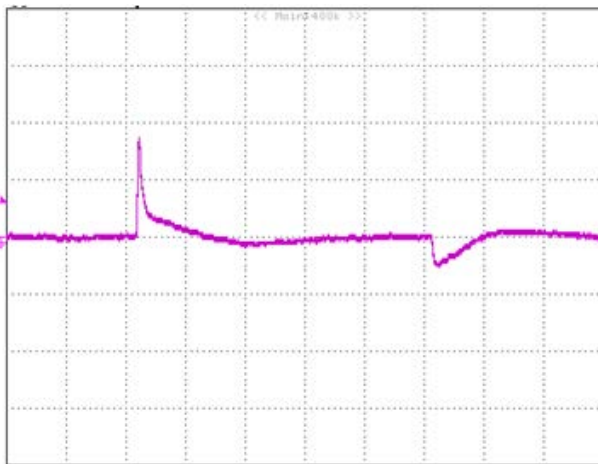

Figure 25: Output voltage response to step-change in load current (25%-75%-25% of 100A load at $V_{in}=12V, V_o=0.7V$; 50mV/div, 200 $\mu S/div, di/dt=2.5A/\mu s$; 2000 μF ceramic C_{out})

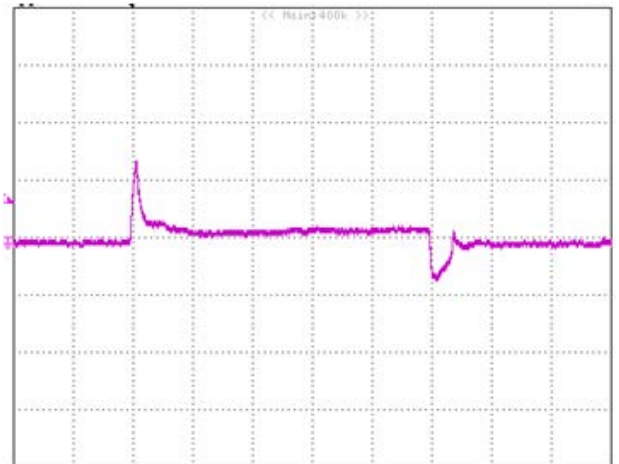

Figure 26: Output voltage response to step-change in load current (25%-75%-25% of 100A load at $V_{in}=12V, V_o=1.2V$; 50mV/div, 200 $\mu S/div, di/dt=2.5A/\mu s$; 2000 μF ceramic C_{out})

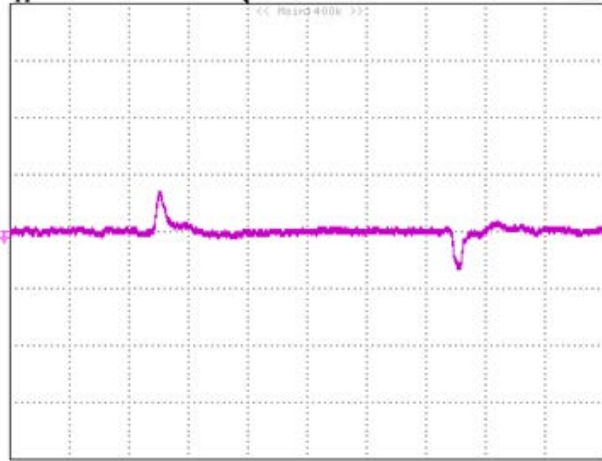

Figure 27: Output voltage response to step-change in load current (25%-75%-25% of 100A load at $V_{in}=12V$ $V_o=1.8V$; 100mV/div, 200uS/div, $di/dt = 2.5A/\mu s$; 2000uF ceramic C_{out})



Figure 28: Output voltage response to step-change in load current (25%-75%-25% of 100A load at $V_{in}=12V$ $V_o=3.3V$; 100mV/div, 200uS/div, $di/dt = 2.5A/\mu s$; 2000uF ceramic C_{out})

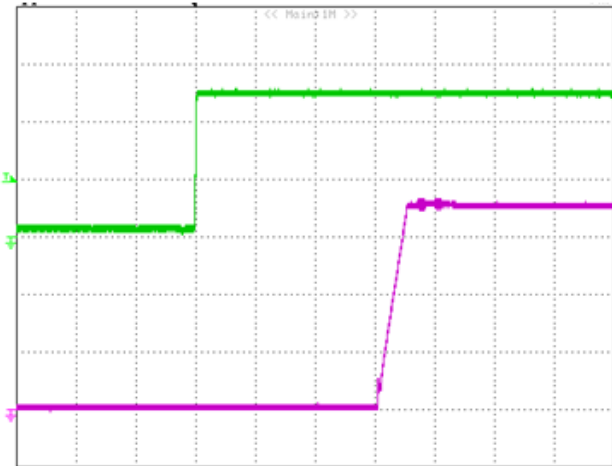

Figure 29: Turn on by enable at $V_{in}=12V$, $V_{out}=0.7V/100A$. Top Trace: Enable, 2V/div; Bottom Trace: V_{out} , 0.2V/div; Time: 20ms/div.

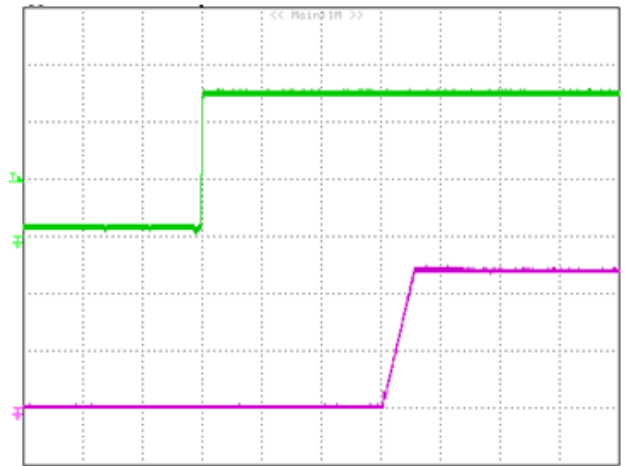

Figure 30: Turn on by enable at $V_{in}=12V$, $V_{out}=1.2V/100A$. Top Trace: Enable, 2V/div; Bottom Trace: V_{out} , 0.5V/div; Time: 20ms/div.

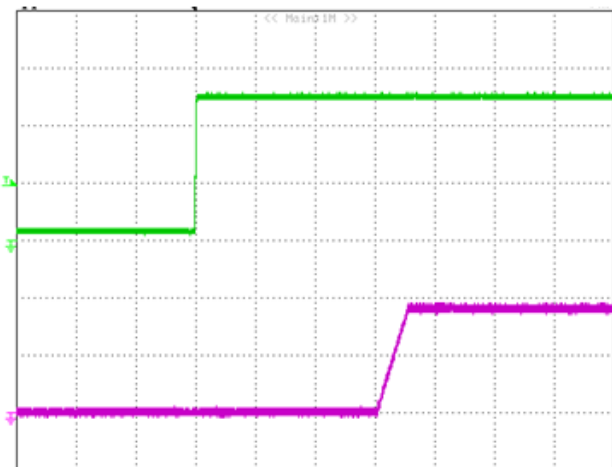

Figure 31: Turn on by enable at $V_{in}=12V$, $V_{out}=1.8V/100A$. Top Trace: Enable, 2V/div; Bottom Trace: V_{out} , 1V/div; Time: 20ms/div.

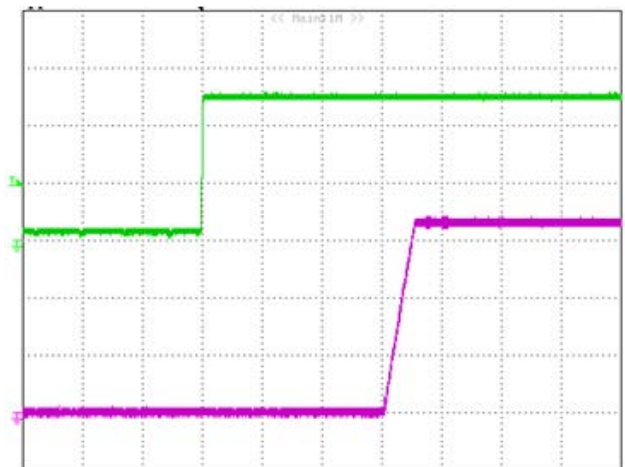

Figure 32: Turn on by enable at $V_{in}=12V$, $V_{out}=3.3V/100A$. Top Trace: Enable, 2V/div; Bottom Trace: V_{out} , 1V/div; Time: 20ms/div.

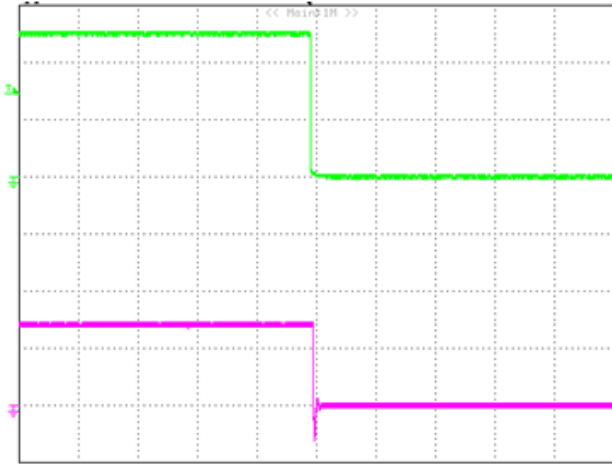

Figure 33: Turn off by enable at $V_{in}=12V$, $V_{out}=0.7V/100A$.
 Top Trace: Enable, 2V/div; Bottom Trace: Vout, 0.5V/div;
 Time: 2ms/div.

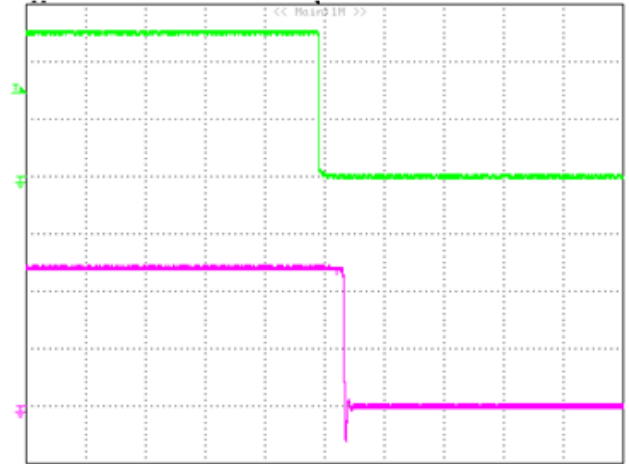

Figure 34: Turn off by enable at $V_{in}=12V$, $V_{out}=1.2V/100A$.
 Top Trace: Enable, 2V/div; Bottom Trace: Vout, 0.5V/div;
 Time: 2ms/div.

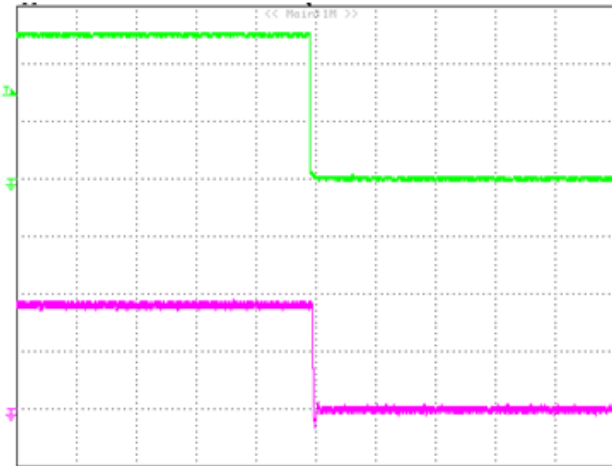

Figure 35: Turn off by enable at $V_{in}=12V$, $V_{out}=1.8V/100A$.
 Top Trace: Enable, 2V/div; Bottom Trace: Vout, 1V/div;
 Time: 2ms/div.

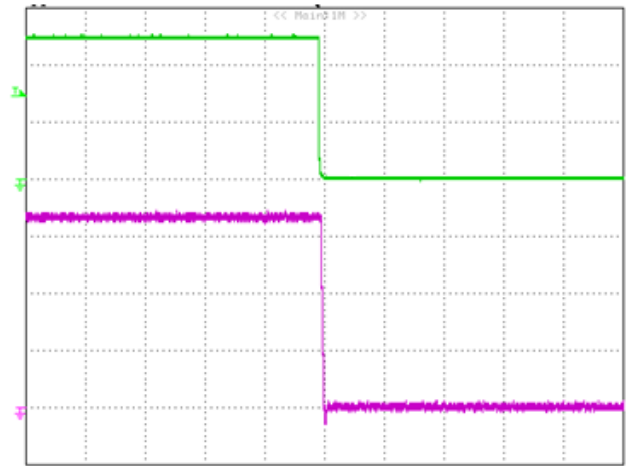

Figure 36: Turn off by enable at $V_{in}=12V$, $V_{out}=3.3V/100A$.
 Top Trace: Enable, 2V/div; Bottom Trace: Vout, 1V/div;
 Time: 2ms/div.

DESIGN CONFIGURATIONS

The DGQ25A is designed using single-phase synchronous buck topology. It is a digital module that can achieve high efficiency, automatic compensation and fast transient response. The module has PMBus interface for system configuration, control and monitoring. The output of DGQ25A can be adjusted in the range of 0.7Vdc to 3.3Vdc by an external resistor from VSET pin to GND or through PMBUS command.

The converter can be turned ON/OFF by remote control signal at ENABLE pin. Positive on/off logic at ENABLE pin will turn on the module while negative on/off logic will turn off the module.

The converter can protect itself by entering Hiccup mode against over current, short circuit condition. Also the module has input OVP and Input UVP function, when input return to the normal working voltage range, the module will auto restart up. The converter will shut down when an Output over voltage protection is detected, Output OVP is latch mode.

The converter has an over temperature protection which can protect itself by shutting down for an over temperature event. There is a typical 25°C hysteresis for the OTP.

DGQ25A has multi-phase load-sharing function and up to 4 modules can in parallel operation.

Due to the single-directional communication on SHARE pin between master and slaves, modules needs to shutdown and power on/off recycling to restart after faults (like OCP, OTP) is triggered in multiphase application.

Safety Considerations

It is recommended that the user to provide a very fast-acting type fuse in the input line for safety. The output voltage set point and the output current in the application could define the amperage rating of the fuse.

Input Source Impedance

The power module should be connected to a low ac-impedance input source. Highly inductive source impedances can affect the stability of the module. An input capacitance must be placed close to the modules input pins to filter ripple current and ensure module stability in the presence of inductive traces that supply the input voltage to the module.

FEATURES DESCRIPTIONS

Enable (On/Off)

DGQ25A has positive on/off logic, pulling the pin low will turn off the unit. With the active high function, the output is guaranteed to turn on if the ENABLE pin is driven above 2.4V. The output will turn off if the ENABLE pin voltage is pulled below 0.8V.

The ENABLE input can be driven in a variety of way as shown in Figures 37.

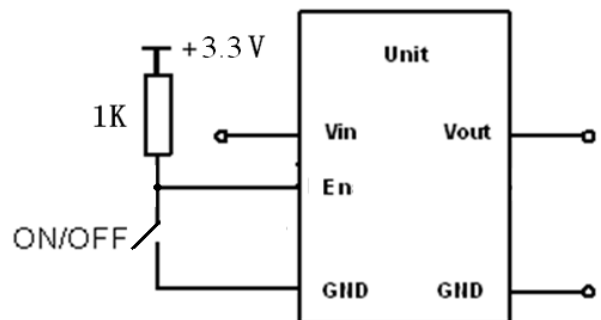

Figure 37: Enable Input drive circuit

Over-Current and Short-Circuit Protection

The DGQ25A has Hiccup over-current and short circuit protection function. When over current /short condition occurs, the module goes into the Hiccup mode. When the fault condition is removed, the module will restart up. When in some serious short (much over 200% of $I_{o,max}$) condition, the controller may reset due to the input and ground on the module can be fluctuating drastically when doing serious short, therefore input power and Enable signal may need to be recycled to restart up after an serious short event.

Input Over Voltage Protection (OVP) and UVLO

The DGQ25A has input over voltage protection function. When input over voltage occurs, the module will shut down. When the input over voltage condition is removed, the module will restart up. Also, the converter has UVLO function at input. When input voltage is below turn-off threshold, the module will shut down and can restart up when input voltage is above turn-on threshold.

Output Over Voltage Protection (OVP)

The converter will shut down when an output over voltage protection is detected. Once the OVP condition

FEATURES DESCRIPTIONS

Over-Temperature Protection

Single module operation: The over-temperature protection prevents the module from thermal damage. If the temperature exceeds the over-temperature threshold the module will shut down. The module will restart once the module is cooling down. There is a typical 25°C hysteresis for the OTP.

Paralleled operation: Because thermal performances of all modules are not exactly the same, one of the slave modules may shut down due to OTP earlier than the others. Then the left modules may go into OCP Hiccup mode. Therefore, input power and Enable signal need to be cycled for paralleled modules to restart up after an OTP event.

Output Voltage Programming

The output voltage of the DGQ25A can be programmed to any voltage between 0.7Vdc and 3.3Vdc by connecting one resistor (shown as Rset in Figure38) between the Rset pin(+) and GND of the module and the typical resistor values are shown in Table 1.

Without this external resistor, the output voltage of the module can be adjusted through PMBUS command.

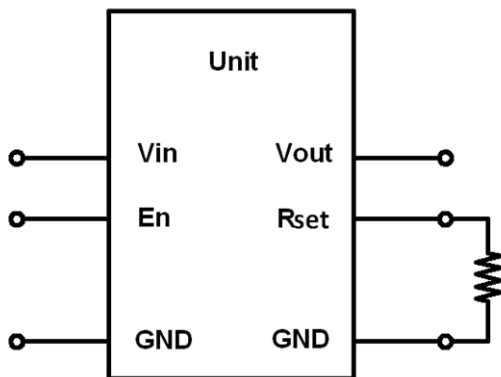

Figure 38: Adjusting Output Voltage

Vout set	Rset ($\pm 1\%$) kohm
0.7V	11.3~11.7
1.0V	51.7~52.9
1.2V	72.4~74.0
1.5V	79.7~81.5
1.8V	85.7~87.5
2.5V	92.1~94.1
3.3V	99.0~101.0

Table 1: Typical Vout set resistor values

FEATURES DESCRIPTIONS (CON.)

Remote Sense

The module provides Vo remote sensing to achieve proper regulation at the load points and reduce effects of distribution losses on output line. In the event of an open remote sense line, the module shall maintain local sense regulation through an internal resistor.

Output Capacitance

There is no output capacitor on the DGQ25A. Please see page 2 for suggested minimum output capacitance.

Synchronization

The module can be synchronized by an external clock. Synchronization is achieved by connecting a clock source to the SYNC pin. The incoming clock signal must be in the 300kHz to 1MHz range and must be stable.

PMBus Communication

The module has a digital PMBus interface to allow the module to be monitored, controlled and configured by the system. The module has 3 PMBus signal lines SDAT, SCLK, SALERT and 1 Address line Rsel. The module supports many standard PMBus commands as listed in the next page.

Paralleling

The module will support multi-phase parallel operation. In this mode, one device provides the master timing signal to which the other devices will align.

The maximum number of parallel phases/modules is four. The current from each phase match within $\pm 10\%$.

The SHARE pin signal is for the purpose of communicating current information between modules. When the modules in parallel operation, the SHARE pins and SYNC pins of all modules will be tied together, please refer to Figure39 for parallel operation set up.

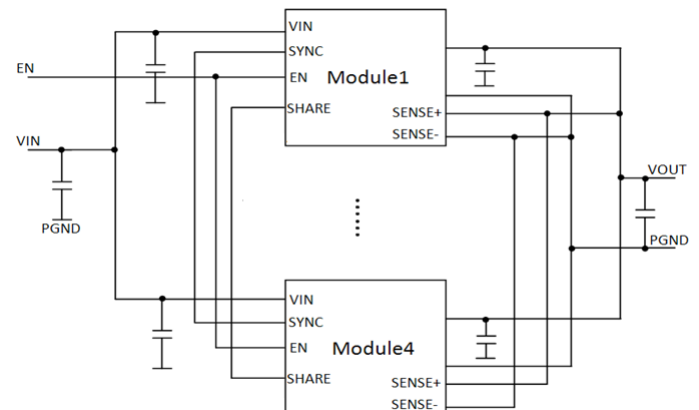

SUPPORTED PMBUS COMMANDS

The main PMBus commands described in the PMBus 1.2 specification are supported by the module. Partial PMBus commands are fully supported; Partial PMBus commands have difference with the definition in PMBus 1.2 specification. All the supported PMBus commands are detail summarized in below table.

Command	Command Code	Command description	Transfer type	Compatible with standard PMBUS or not?	Data Format	Default value	Range limit	Data units	Exponent	Note
OPERATION	0x01	Turn the module on or off by PMBUS command	R/W byte	yes	direct	0x40	/	/	/	/
ON_OFF_CONFIG	0x02	Configures the combination of primary on/off pin and PMBUS command	Read byte	yes	direct	0x17	/	/	/	/
CLEAR_FAULTS	0x03	Clear any fault bits that have been set	Send byte	Yes	direct	/	/	/	/	/
WRITE_PROTECT	0x10	control writing to the PMBus device	R/W byte	yes	direct	0	/	/	/	/
STORE_DEFAULT_ALL	0x11	Stores operating parameters from RAM to data flash	Send byte	Yes	direct	/	/	/	/	/
RESTORE_DEFAULT_ALL	0x12	Restores operating parameters from data flash to RAM	Write byte	Yes	direct	/	/	/	/	This command can't be issued when the power unit is running.
STORE_USER_ALL	0x15	copy the entire contents of the Operating Memory to the matching locations in the non-volatile User store memory	Send byte	yes	direct	/	/	/	/	/
RESOTRE_USER_ALL	0x16	copy the entire contents of the non-volatile User Store memory to the matching locations in the Operating Memor	write byte	yes	direct	/	/	/	/	/
CAPABILITY	0x19	determine some key capabilities of a PMBus device.	Read byte	yes	direct	0xA0	/	/	/	/
VOUT_MODE	0x20	To read Vo data format	Read byte	Yes	mode+exp	0x14	/	/	/	/
VOUT_COMMAND	0x21	Set the output voltage	R/W word	Yes	Vlinear	1.2	/	Volts	/	/

VOUT_TRIM	0x21	apply a fixed offset voltage to the output voltage command value	R/W word	yes	Linear	0	/	/	/	/
VOUT_CAL_OFFSET	0x22	apply a fixed offset voltage to the output voltage command value	R/W word	yes	Linear	0.012	/	/	/	/
VOUT_MAX	0x23	sets an upper limit on the output voltage the unit can command regardless of any other commands or combinations	R/W word	yes	linear	5	/	/	/	/
VOUT_MARGIN_HIGH	0x25	Set the output voltage	R/W word	Yes	Vlinear	1.3	/	Volts	/	/
VOUT_MARGIN_LOW	0x26	Set the output voltage	R/W word	Yes	Vlinear	1	/	Volts	/	/
VOUT_TRANSITION_RATE	0x27	sets the rate in mV/ μ s at which the output should change voltage	R/W word	yes	Linear	0.01	/	/	/	/
VOUT_DROOP	0x28	sets the rate, in mV/A at which the output voltage decreases with increasing output current	R/W word	yes	Linear	0	/	/	/	/
FREQUENCY_SWITCH	0x33	sets the switching frequency, in kHz,	R/W word	yes	Linear	500000	/	/	/	/
VIN_ON	0x35	Set the turn on voltage threshold of V_{in} under voltage lockout	R/W word	Yes	Linear	7.5	/	V	/	VIN_ON should be higher than VIN_OFF, and keep 1V hysteresis.
VIN_OFF	0x36	Set the turn off voltage threshold of V_{in} under voltage lockout	R/W word	Yes	Linear	6.5	/	V	/	VIN_ON should be higher than VIN_OFF, and keep 1V hysteresis.

INTERLEAVE	0x37	arrange multiple units so that their switching periods can be distributed in time	R/W word	yes	Direct	0	/	/	/	/
IOUT_CAL_GAIN	0x38	Used to calibrate DCR	R/W word	Yes	Linear	0.00029	/	/	/	/
IOUT_CAL_OFFSET	0x39	null out any offsets in the output current sensing circuit.	R/W word	Yes	Linear	0	/	/	/	/
VOUT_OV_FAULT_LIMIT	0x40	Set the output overvoltage fault threshold.	R/W word	Yes	Vlinear	1.44	/	V	/	/
VOUT_OV_FAULT_RESPONSE	0x41	Instructs what action to take in response to an output overvoltage fault.	R/W byte	Refer to below description;	Direct	0x80	/	N/A	/	/
VOUT_UV_FAULT_LIMIT	0x44	sets the value of the output voltage at the sense or output pins that causes an output undervoltage fault	R/W word	yes	Vlinear	0.1	/	/	/	/
VOUT_UV_FAULT_RESPONSE	0x45	action to take in response to an output undervoltage fault	R/W byte	yes	direct	0	/	/	/	/
IOUT_OC_FAULT_LIMIT	0x46	Set the output overcurrent fault threshold.	R/W word	Yes	Linear	31.5	/	A	/	Must be greater than IOUT_OC_WARN_LIMIT value
IOUT_OC_FAULT_RESPONSE	0x47	Instructs what action to take in response to an output overcurrent fault.	R/W byte	Refer to below description;	Bit field	0xBF	/	N/A	/	/
OT_FAULT_LIMIT	0x4F	Set the over temperature fault threshold.	R/W word	Yes	TEMP Linear	120	/	Deg. C	/	Must be greater than OT_WARN_LIMIT value
OT_FAULT_RESPONSE	0x50	Instructs what action to take in response to an	R/W byte	Refer to below	Bit field	0XC0	/	N/A	/	/

		over temperature fault.		descriptio n;						
OT_WARN_LIMIT	0x51	Set a threshold causing a temperature high warning.	R/W word	Yes	TEMP Linear	95	/	Deg. C	/	Must be less than OT_FAULT_LI MIT value
VIN_OV_FAULT_LIMIT	0x55	Set the input overvoltage fault threshold.	R/W word	Yes	Linear	14	/	V	/	/
VIN_OV_FAULT_RESPON SE	0x56	Instructs what action to take in response to an input overvoltage fault.	R/W byte	Refer to below descriptio n;	Direct	0XC0	/	N/A	/	/
VIN_UV_FAULT_LIMIT	0x59	sets the value of the input voltage that causes input undervoltage fault	R/W word	Refer to below descriptio n;	Linear	5.5	/	/	/	/
VIN_UV_FAULT_RESPON SE	0x5A	action to take in response to an input undervoltage fault	R/W byte	Refer to below descriptio n;	direct	0xC0	/	/	/	/
POWER_GOOD_ON	0x5E	Sets the output voltage at which the bit 3 of STATUS_WORD high byte should be asserted.	R/W word	Yes	Vlinear	1.08	/	V	/	/
POWER_GOOD_OFF	0x5F	Sets the output voltage at which the bit 3 of STATUS_WORD high byte should be negated.	R/W word	Yes	Vlinear	0.98	/	V	/	/
TON_DELAY	0x60	Sets the time from a start condition is received until the output voltage starts to rise	R/W word	Yes	Linear	0.004	/	ms	/	/
TON_RISE	0x61	Sets the time from the output starts to rise until the voltage has entered the regulation band.	R/W word	Yes	Linear	0.004	/	ms	/	/
TON_MAX_FAULT_LIMIT	0x62	sets an upper limit, in milliseconds, on how	R/W word	Refer to below	direct	500	/	/	/	/

		long the unit can attempt to power up the output without reaching the output undervoltage fault limit		description						
TON_MAX_FAULT_RESPONSE	0x63	instructs the device on what action to take in response to a TON_MAX fault	R/W Byte	Refer to below description	Direct	0xBF	/	/	/	/
TOFF_DELAY	0x64	sets the delay time between loss of enable condition and the beginning of the output ramp-down	R/W word	yes	Linear	0	/	/	/	/
TOFF_FALL	0x65	The TOFF_FALL command sets the ramp-down time from regulation at VOUT_COMMAND to 0V	R/W word	yes	Linear	0.004	/	/	/	/
STATUS_BYTE	0x78	returns one byte of information with a summary of the most critical faults	Read byte	Yes	Direct	/	/	/	/	/
STATUS_WORD	0x79	Returns the information with a summary of the module's fault/warning	Read word	Yes	Direct	/	/	/	/	/
STATUS_VOUT	0x7A	Returns the information of the module's output voltage related fault/warning	Read byte	Yes;	Direct	/	/	/	/	/
STATUS_IOUT	0x7B	Returns the information of the module's output current related fault/warning	Read byte	Yes	Direct	/	/	/	/	/
STATUS_INPUT	0x7C	Returns the information of the module's input over voltage and under voltage fault	Read byte	Yes	Direct	/	/	/	/	/

STATUS_TEMPERATURE	0x7D	Returns the information of the module's temperature related fault/warning	Read byte	Yes	Direct	/	/	/	/	/
STATUS_CML	0x7E	Returns the information of the module's communication related faults.	Read byte	Yes	Direct	/	/	/	/	/
STATUS_MFR_SPECIFIC	0x80	returns one data byte with the status that manufacturer defined	Read byte	Refer to below description;	Direct	/	/	/	/	/
READ_VIN	0x88	Returns the input voltage of the module	Read word	Yes	Vlinear	/	/	Volts	/	/
READ_VOUT	0x8B	Returns the output voltage of the module	Read word	Yes	Vlinear	/	/	Volts	/	/
READ_IOUT	0x8C	Returns the output current of the module	Read word	Yes	Linear	/	/	Amps	/	/
READ_TEMPERATURE_1	0x8D	report its internal (i.e. die) temperature	Read word	Yes	Linear	/	/	Deg. C	/	/
READ_TEMPERATURE_2	0x8E	report external temperature as measured by an external diode junction	Read word	Yes	Linear	/	/	Deg. C	/	/
READ_DUTY_CYCLE	0x94	Read the duty cycle value	Read word	yes	Linear	/	/	%	/	/
READ_FREQUENCY	0x95	Read the switching frequency	Read byte	yes	Linear	/	/	MHz	/	/
PMBUS_REVISION	0x98	Reads the revision of the PMBus	Read byte	Yes	Direct	0x42	/	/	/	/
MFR_ID	0x99	manufacturer's ID	Read write block	yes	ASCII string	Null	/	/	/	/
MFR_MODEL	0x9A	manufacturer's model number	Read write block	yes	ASCII string	Null	/	/	/	/
IC_DEVICE_ID	0xAD	the type or part number of an IC embedded within a PMBus that is used for the PMBus interface	Read write block	yes	ASCII string	Null	/	/	/	/
MFR_REVISION	0x9B	manufacturer's revision number	Read Write	Yes	ASCII string	Null	/	/	/	/

			Block							
MFR_LOCATION	0x9C	manufacturing location of the device	Read Write Block	Yes	ASCII string	Null	/	/	/	/
MFR_DATE	0x9D	the date the device was manufactured.	Read Write Block	Yes	ASCII string	Null	/	/	/	/
MFR_SERIAL	0x9E	manufacturer's serial number of the device	Read Write Block	Yes	ASCII string	Null	/	/	/	/
IC_DEVICE_REV	0xAE	the type or part number of an IC embedded within a PMBus that is used for the PMBus interface	Read Block	Yes	ASCII string	Null	/	/	/	/
ADAPTIVE_MODE	0xD0	configures the automatic tuning features of the MAX15301-CCB-CCB	Read/Write Word	No	Direct	0x024B	/	/	/	/
FEEDBACK_EFFORT	0xD3	allows some user adjustment of the tradeoff between transient response, load regulation, and output noise.	Read Byte	No	Linear	0.3	/	/	/	/
MANUF_CONF	0xE0	allow password-based write-protection on a per-command basis	Read/Write Block	No	Direct	0	/	/	/	/
MANUF_LOCK	0xE1	contains the password value for the "manufacturer" PMBus command security level	Write Word	No	Direct	0	/	/	/	/
MANUF_PASSWD	0xE2	the "key" or password-attempt command used to unlock the "manufacturer" security level	Read/Write Word	No	Direct	0	/	/	/	/
USER_CONF	0xE3	allow password-based write-protection on a per-command basis	Read/Write Block	No	Direct	0	/	/	/	/
USER_LOCK	0xE4	contains the password	Read	No	Direct	0	/	/	/	/

		value for the "user" PMBus command security level	Word							
USER_PASSWD	0xE5	the "key" or password-attempt command used to unlock the "user" security level	Read Word	No	Direct	0	/	/	/	/
SECURITY_LEVEL	0xE6	shows the present security level of password protection for all writeable PMBus commands	Read Byte	No	Direct	0	/	/	/	/
ZETAP	0xE8	sets the damping ratio for the closed-loop response	Read/Write Byte	No	Linear	1.5	/	/	/	/
RESTORE_MAXIMAL	0xEA	Load contents of the MAXIM store into working memory	Send Byte	No	Direct	0	/	/	/	/
EXT_TEMP_CAL	0xF8	External temperature sense signal calibration gain and offset.	R/W Block	No	Linear	1.030000e+00, 0.0000e+00	/	/	/	/
SENSEFET_PARAMS	0xF9	Delta Cisco output current Sense switch, offset and gain (m, b, mV/A)	R/W Block	No	Linear	1.0000e+000.0 000e+003.000 0e+01	/	/	/	/

THERMAL CONSIDERATIONS

Thermal management is an important part of the system design. To ensure proper, reliable operation, sufficient cooling of the power module is needed over the entire temperature range of the module. Convection cooling is usually the dominant mode of heat transfer.

Hence, the choice of equipment to characterize the thermal performance of the power module is a wind tunnel.

Thermal Testing Setup

Delta's DC/DC power modules are characterized in heated vertical wind tunnels that simulate the thermal environments encountered in most electronics equipment. This type of equipment commonly uses vertically mounted circuit cards in cabinet racks in which the power modules are mounted.

The following figure shows the wind tunnel characterization setup. The power module is mounted on a test PWB and is vertically positioned within the wind tunnel. The space between the neighboring PWB and the top of the power module is constantly kept at 6.35mm (0.25").

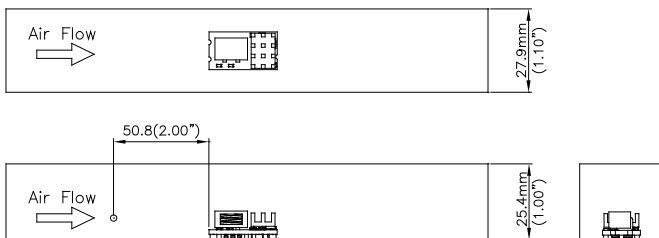

Figure 40: Wind tunnel test setup

Thermal Derating

Heat can be removed by increasing airflow over the module. To enhance system reliability; the power module should always be operated below the maximum operating temperature. If the temperature exceeds the maximum module temperature, reliability of the unit may be affected.

THERMAL CURVES

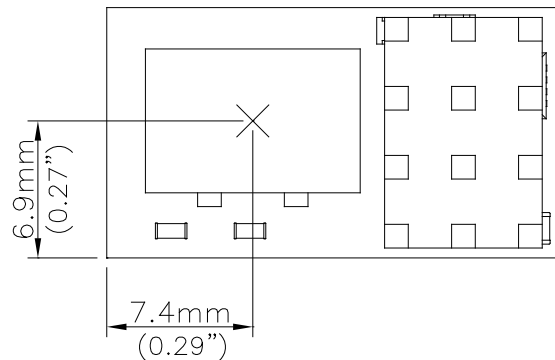

Figure 41: * Hot spot temperature measured point.

The allowed maximum hot spot temperature is defined at 115°C.

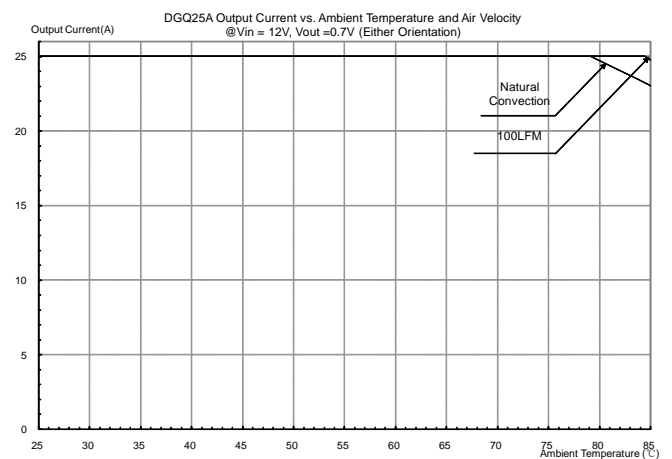

Figure 42: Output current vs. ambient temperature and air velocity @ $V_{in}=12V$, $V_{out}=0.7V$ (Either Orientation)

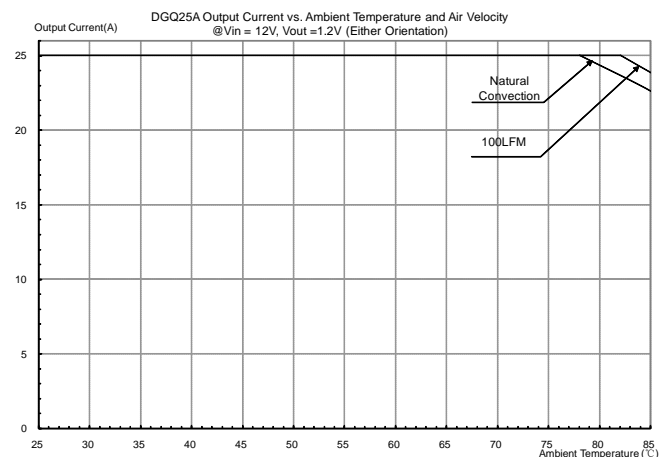

Figure 43: Output current vs. ambient temperature and air velocity @ $V_{in}=12V$, $V_{out}=1.2V$ (Either Orientation)

THERMAL CURVES

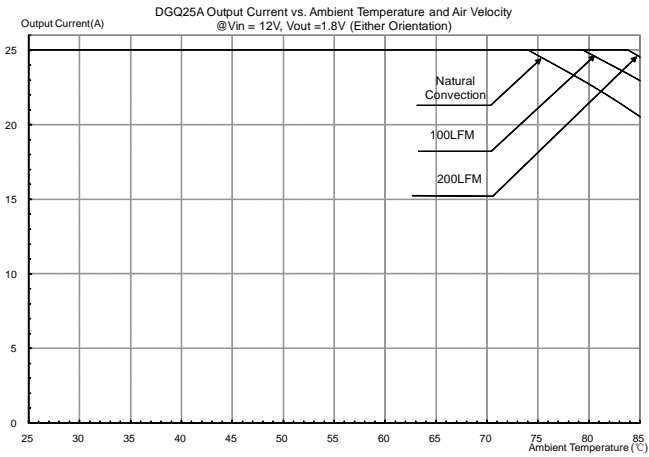

Figure 44: Output current vs. ambient temperature and air velocity @ Vin=12V, Vout=1.8V (Either Orientation)

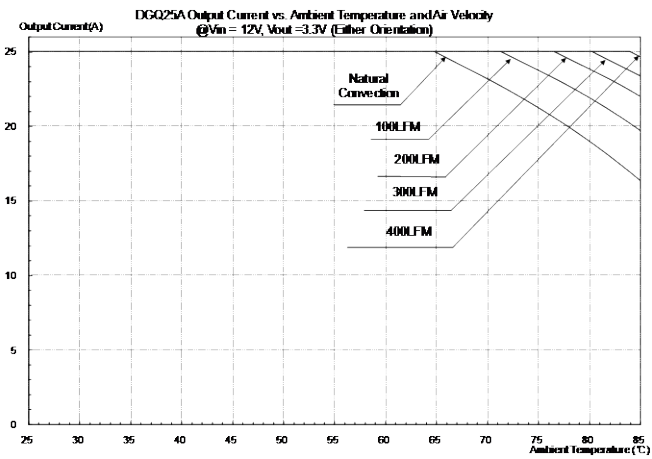
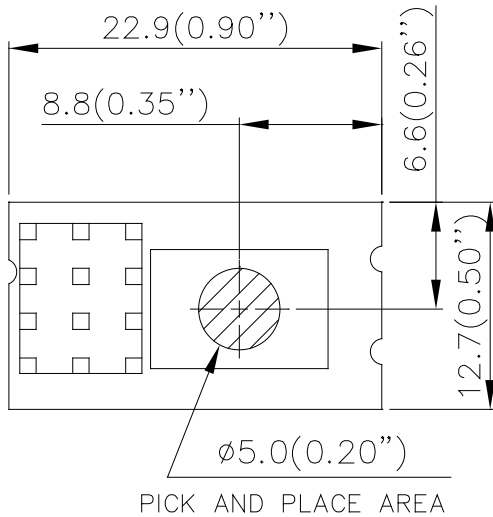

Figure 45: Output current vs. ambient temperature and air velocity @ Vin=12V, Vout=3.3V (Either Orientation)

MECHANICAL CONSIDERATIONS

PICK AND PLACE LOCATION



RECOMMENDED PAD LAYOUT

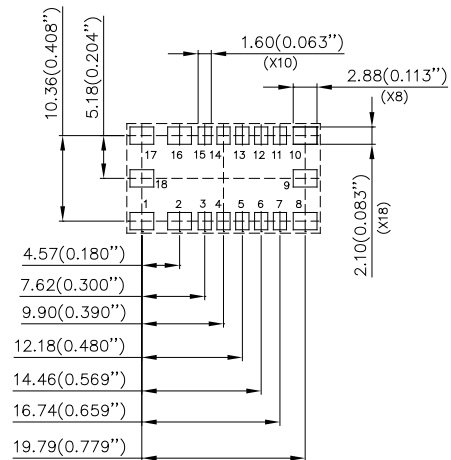

RECOMMENDED LAYOUT

NOTES:
 DIMENSIONS ARE IN MILLIMETERS AND (INCHES)
 TOLERANCES: X.Xmm±0.5mm(X.XX in.±0.02 in.)
 X.XXmm±0.25mm(X.XXX in.±0.010 in.)

SURFACE MOUNT TAPE & REEL

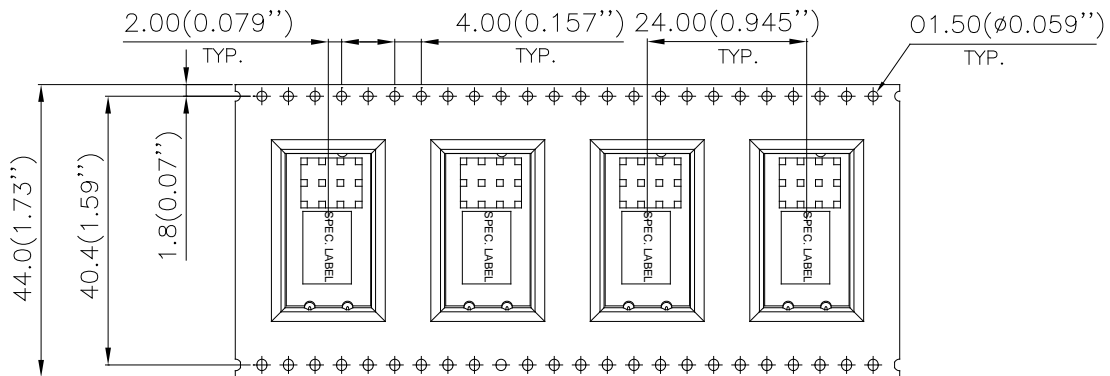

FEED DIRECTION →

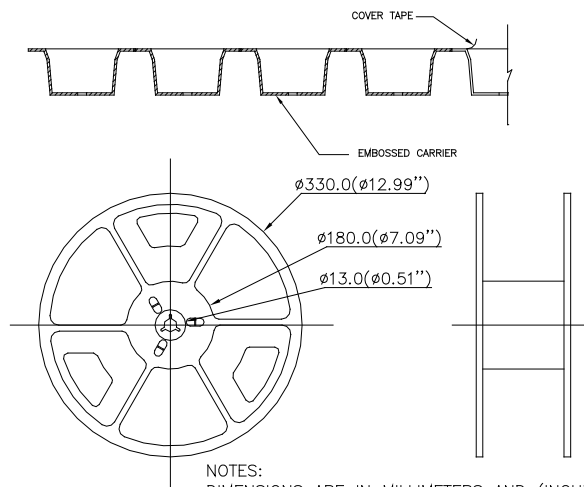

NOTES:
 DIMENSIONS ARE IN MILLIMETERS AND (INCHES)
 TOLERANCES: X.Xmm±0.5mm(X.XX in.±0.02 in.)
 X.XXmm±0.25mm(X.XXX in.±0.010 in.)

LEADED (SN/PB) PROCESS RECOMMEND TEMP. PROFILE

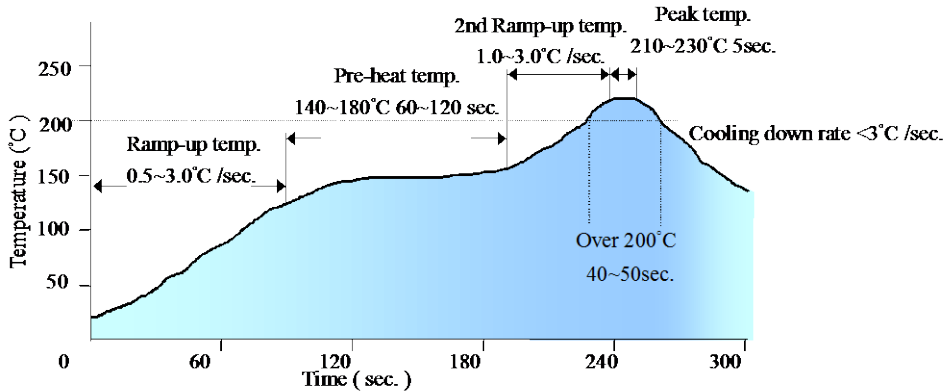

Note: The temperature refers to the pin of DGQ25A, measured on the pin +Vout joint.

LEAD FREE (SAC) PROCESS RECOMMEND TEMP. PROFILE

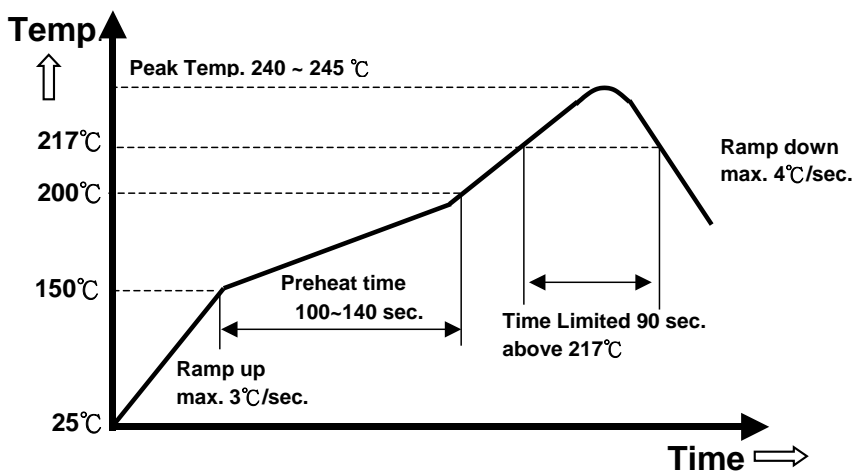

Note: The temperature refers to the pin of DGQ25A, measured on the pin +Vout joint.

MECHANICAL DRAWING

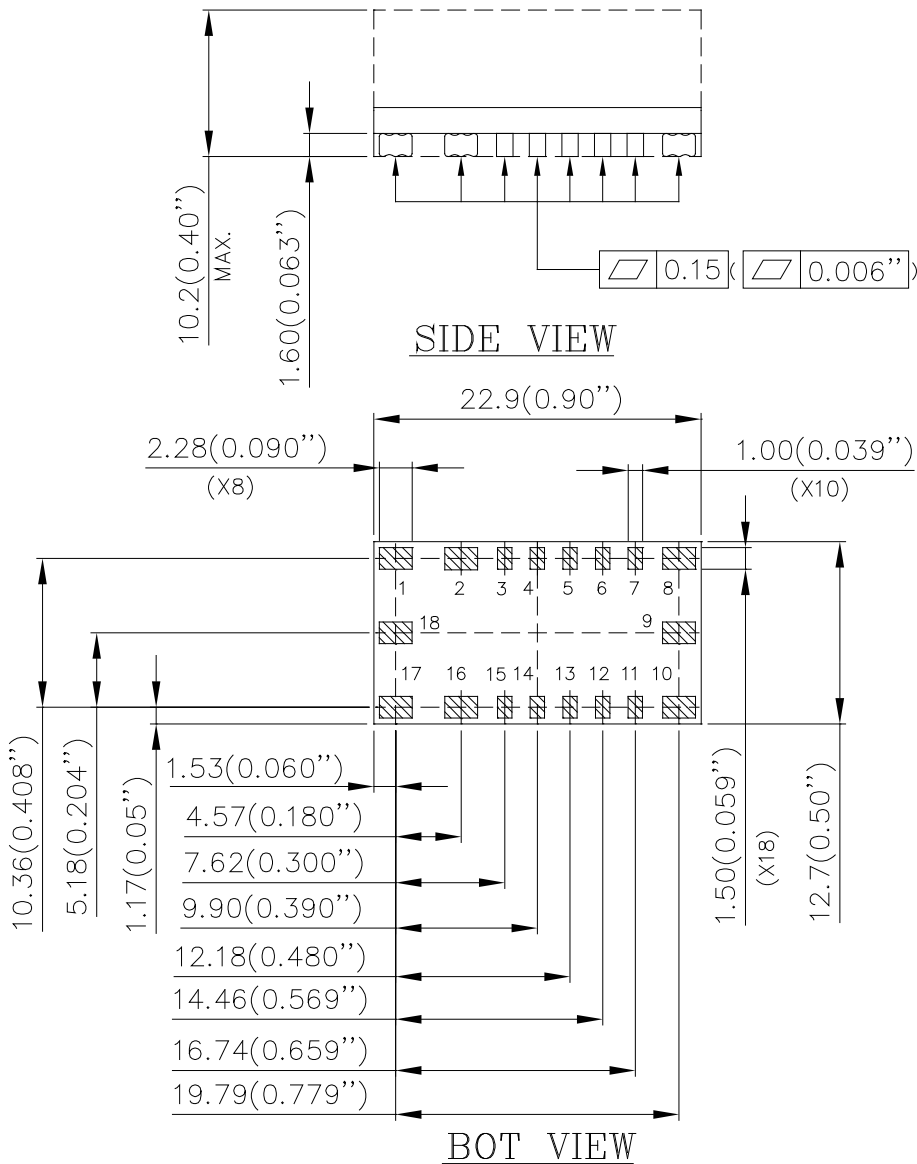

PIN#	FUNCTION
1	GND
2	GND
3	EN
4	SCLK
5	SDAT
6	SALERT
7	RSEL
8	OUT
9	OUT
10	OUT
11	SENSE+
12	SENSE-
13	RSET
14	SHARE
15	SYNC
16	GND
17	GND
18	VIN

NOTES:
 DIMENSIONS ARE IN MILLIMETERS AND (INCHES)
 TOLERANCES: X.Xmm±0.5mm(X.XX in.±0.02 in.)
 X.XXmm±0.25mm(X.XXX in.±0.010 in.)

Note: All pins are copper alloy with Matte Tin plated over Ni under-plating.

PART NUMBERING SYSTEM

DGQ	12	S	0A0	S	25	P	F	A
Product Series	Input Voltage	Numbers of Outputs	Output Voltage	Package Type	Output Current	On/Off logic		Option Code
DGQ – Digital 25A	12- 8.0V ~12.8V	S - Single	0A0 - Programmable	S - SMD	25 -25A	P - positive (Default)	F- RoHS 6/6 (Lead Free)	A - Standard function

MODEL LIST

Model Name	Input Voltage	Output Voltage	Output Current	Total Height	RoHS 6/6 complaint	Efficiency 12Vin, 3.3Vout @ 100% load
DGQ25A	8.0 ~ 12.8Vdc	0.7V ~ 3.3V	25A	10.2mm(0.4")	Yes	93.7%

CONTACT: www.deltaww.com/dcdc

USA:

Telephone:
East Coast: 978-656-3993
West Coast: 510-668-5100
Fax: (978) 656 3964
Email: DCDC@delta-corp.com

Europe:

Telephone: +31 (0)20 655 09 67
Fax: +31 (0)20 655 09 99
Email: DCDC@delta-es.com

Asia & the rest of world:

Telephone: +886 3 4526107 x6220~6224
Fax: +886 3 4513485
Email: DCDC@delta.com.tw

WARRANTY

Delta offers a two (2) year limited warranty. Complete warranty information is listed on our web site or is available upon request from Delta.

Information furnished by Delta is believed to be accurate and reliable. However, no responsibility is assumed by Delta for its use, nor for any infringements of patents or other rights of third parties, which may result from its use. No license is granted by implication or otherwise under any patent or patent rights of Delta. Delta reserves the right to revise these specifications at any time, without notice.